

Versatile Multi-Purpose Robot

- 22kg maximum payload capacity with superior wrist torque
- Large working envelope with a maximum reach of 1722mm
- Superior performance with high-speed motion and high-positioning accuracy
- Compact arm reduces interference with equipment
- Internal air supply lines and cabling supports numerous applications
- Optional internal pneumatic valves remove shoulder mounted valve packages
- IP65 compliant

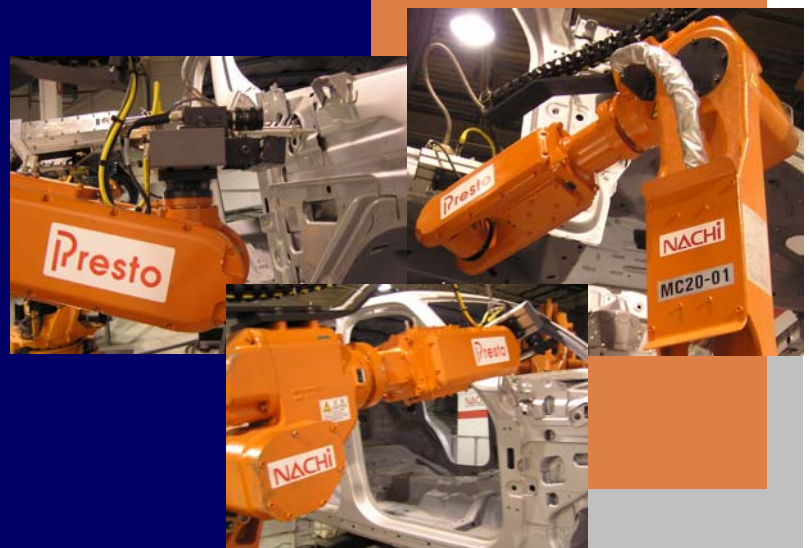
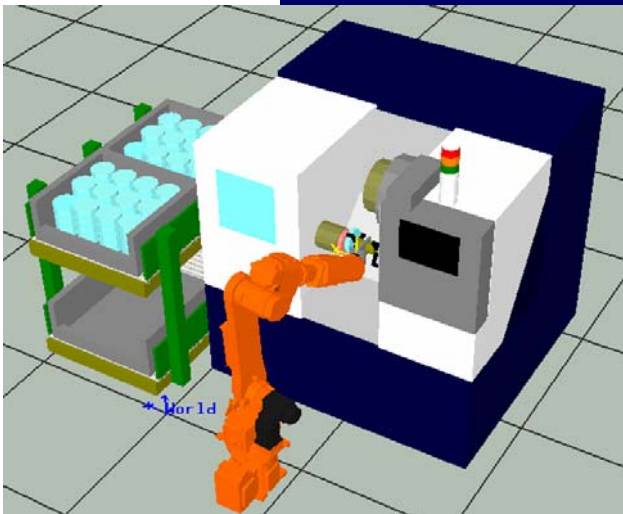

Presto MC20-01 Robot

Item		Specifications
Robot Model		MC20-01
Construction		Articulated
Number of Axis		6
Drive System		AC servo motor
Maximum Working Envelope	J1	±180°
	J2	+145°~-60°
	J3	+240°~-161°
	J4	±180°
	J5	±139°
	J6	±360°
Maximum Speed	J1	±170°/sec
	J2	±170°/sec
	J3	±170°/sec
	J4	±360°/sec
	J5	±360°/sec
	J6	±602°/sec
Maximum Payload*		20kg
Allowable Static Load Torque	J4	5kg
	J5	5kg
	J6	2.5kg
Allowable Moment of Inertia**	J4	1.6kg·m ²
	J5	1.6kg·m ²
	J6	0.8kg·m ²
Position Repeatability		±0.06mm / ±0.0023"
Air Pressure		<=5.0kgf/cm ²
Ambient Temperature		0~45°C
Installation		Floor, Ceiling
Dustproof / Waterproof ***		IP65
Robot Weight		230kg

*Operating range is limited according to the payload weight

**This conforms to JIS B 8432

***Liquid such as organic compound, acidity, alkalinity, chlorine, or gasoline cutting fluid that deteriorates the seal material cannot be used

