

NACHI

Standard specifications

**MC20-01-AX20/FD11
MC10L-01-AX20/FD11
MC12S-01-AX20/FD11**

14th edition

NACHI-FUJIKOSHI CORP.

1309, SMCEN-017-014,001



Table of contents

1. Outline.....	1
2. Basic specifications.....	2
3. Robot dimensions and working envelope.....	3
4. Detail of tool mounting plate.....	6
5. Installation Procedure.....	7
6. Maximum wrist load.....	12
7. Option specifications.....	16
8. Application wiring and tubing diagram (standard).....	17
9. Transport procedure.....	20
10. Installation (specification which contains a robot).....	22
11. Consuming power (Robot + Controller).....	22
12. Paint color.....	22
13. Warranty.....	22

1. Outline

NACHI ROBOT has used mechatronic techniques, cultivated throughout the last few decades, to supply robots suited for industries utilizing welding, spray painting and the material handling techniques.

The MC robot is a 6 axes robot that has characteristics like listed as below.

- Simple structure
- High speed
- High accuracy
- Suitable for material handling applications

Installation \ Arm type Load weight	Standard arm 20 kg (Max.22Kg)	Long arm 10 kg	Short arm 12 kg
Floor mount Ceiling mount	MC20-01	MC10L-01	MC12S-01 (*1)
Wall mount	×	×	

*1; If wall mount is selected, wall mount option (OP-S7-010) is necessary.

■ Characteristic

1. This robot is designed so that the size of the motion range is similar to that of one worker. Therefore, it becomes possible to make a compact robot cell. And, this robot is also suitable for a loading application for randomly workpieces.
2. The wide motion range lightens the limitation of the actual motion range. And examining applicability becomes easier than before.
3. The wrist and the main body become “Dust-proof / Drip-proof performance (IP65 corresponding)”, and the application that can be applied has extended.
4. The motion range suitable for the weight of the workpieces or tools can be selected. Because of this, it becomes possible to use a heavier workpiece, double hand, etc.

2. Basic specifications

Item		Specifications		
Robot model		MC20-01	MC10L-01	MC12S-01
Construction		Articulated		
Number of axis		6		
Drive system		AC servo motor		
Max. working envelope	Axis 1	± 3.14 rad ($\pm 180^\circ$) ^{*4}		
	Axis 2	$+1.05 \sim -2.53$ rad ($+60 \sim -145^\circ$) ^{*4}		
	Axis 3	$+4.22 \sim -2.84$ rad ($+242 \sim -163^\circ$)	$+4.22 \sim -2.69$ rad ^{*4} ($+242 \sim -154^\circ$)	
	Axis 4	± 3.14 rad ($\pm 180^\circ$) ^{*4}		
	Axis 5	± 2.42 rad ($\pm 139^\circ$) ^{*4}		
	Axis 6	± 6.28 rad ($\pm 360^\circ$) ^{*4}		
Max. speed	Axis 1	2.96 rad/s (170 °/s)	2.62 rad/s (150 °/s)	3.49 rad/s (200 °/s)
	Axis 2	2.96 rad/s (170 °/s)		
	Axis 3	2.96 rad/s (170 °/s)		
	Axis 4	6.28 rad/s (360 °/s)	6.46 rad/s (370 °/s)	
	Axis 5	6.28 rad/s (360 °/s)	6.46 rad/s (370 °/s)	
	Axis 6	10.5 rad/s (600 °/s)	12.2 rad/s (700 °/s)	
Max. pay load ^{*1}		20 kg (Max. 22 kg)	10 kg	12 kg
Allowable static load torque	Axis 4	49 N·m	24.5 N·m	28 N·m
	Axis 5	49 N·m	24.5 N·m	28 N·m
	Axis 6	23.5 N·m	12 N·m	13 N·m
Allowable moment of inertia ^{*2}	Axis 4	1.6 kg·m ²	1.6 kg·m ²	1.3 kg·m ²
	Axis 5	1.6 kg·m ²	1.6 kg·m ²	1.3 kg·m ²
	Axis 6	0.8 kg·m ²	0.7 kg·m ²	0.47 kg·m ²
Position repeatability ^{*3}		± 0.06 mm		
Maximum air pressure		Not more than 0.49 MPa (5.0 kgf / cm ²)		
Installation		Floor mount, Ceiling mount		Floor mount, Ceiling mount, Wall mount ^{*4}
Ambient conditions		Temperature: 0 to 45 °C ^{*5} Humidity: 20 to 85%RH (No dew condensation allowed) Vibration to the installation face: Not more than 0.5G (4.9 m/s ²)		
Dust-proof / Drip-proof performance ^{*6}		IP65 equivalent (dust and drain proof-type)		
Robot mass		220 kg	225 kg	210 kg (Wall mount ^{*4} ; 330 Kg)

1 [rad] = 180 / π [°], 1 [N·m] = 1 / 9.8 [kgf·m]

- On controller display, axis 1 to 6 is displayed J1 to J6 for each.

- The specification and externals described in this specifications might change without a previous notice for the improvement.

*1: Operating range is limited according to the payload weight. *2: The Allowable moment of inertia of a wrist changes with load conditions of a wrist. *3: This value conforms to "JIS B 8432" standard. *4: If wall mount is selected, wall mount option (OP-S7-010) is necessary. Working envelope and robot mass is different from those of floor mount and ceiling mount. Please refer to "3 Robot dimensions and working envelope" for detail. *5: Permitted height is not higher than 1,000m above sea level. If used in higher place, permitted temperature is affected by height. *6: Liquid such as organic compound, acidity, alkalinity, chlorine or gasoline cutting fluid which deteriorates the seal material are not available to use.

3. Robot dimensions and working envelope

MC20-01

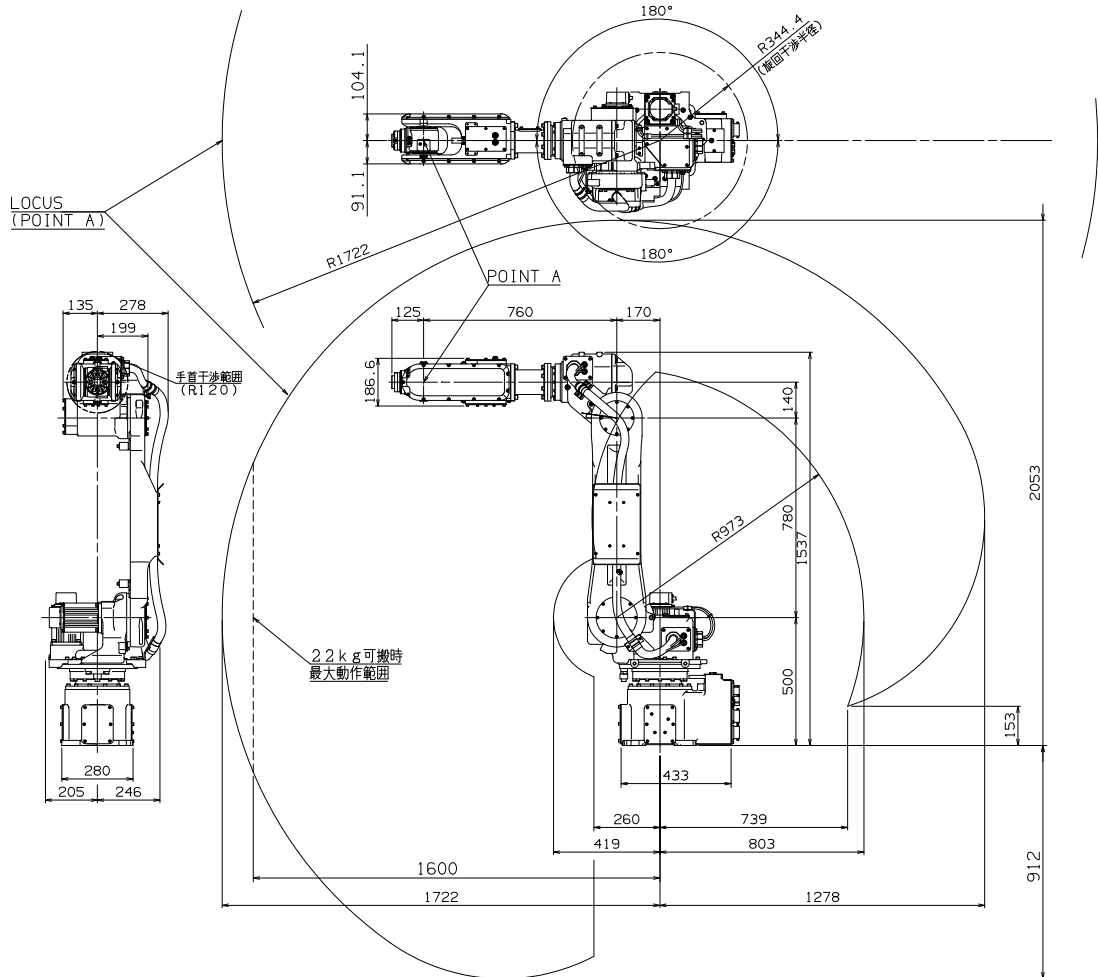

MC10L-01

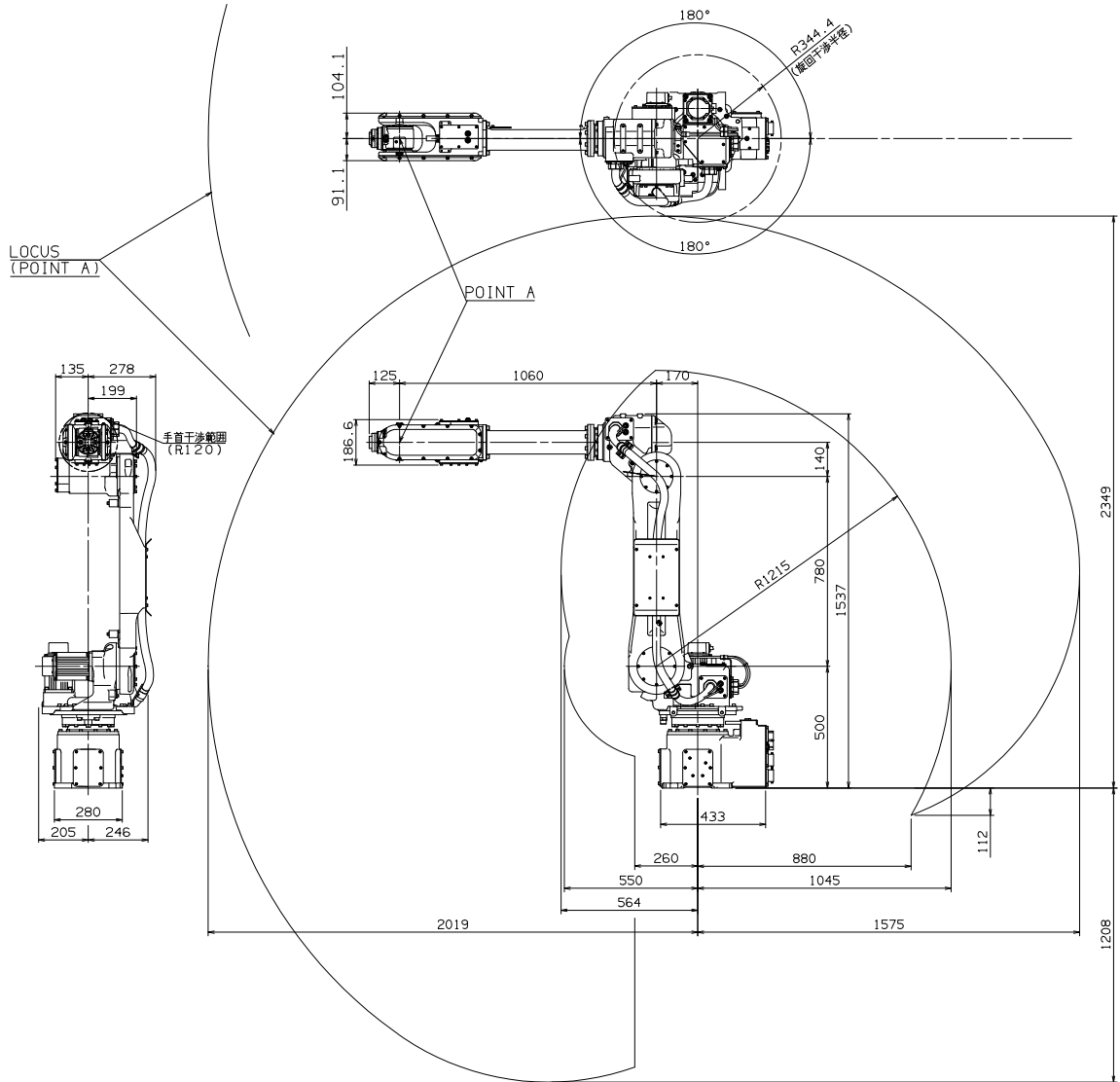

MC12S-01

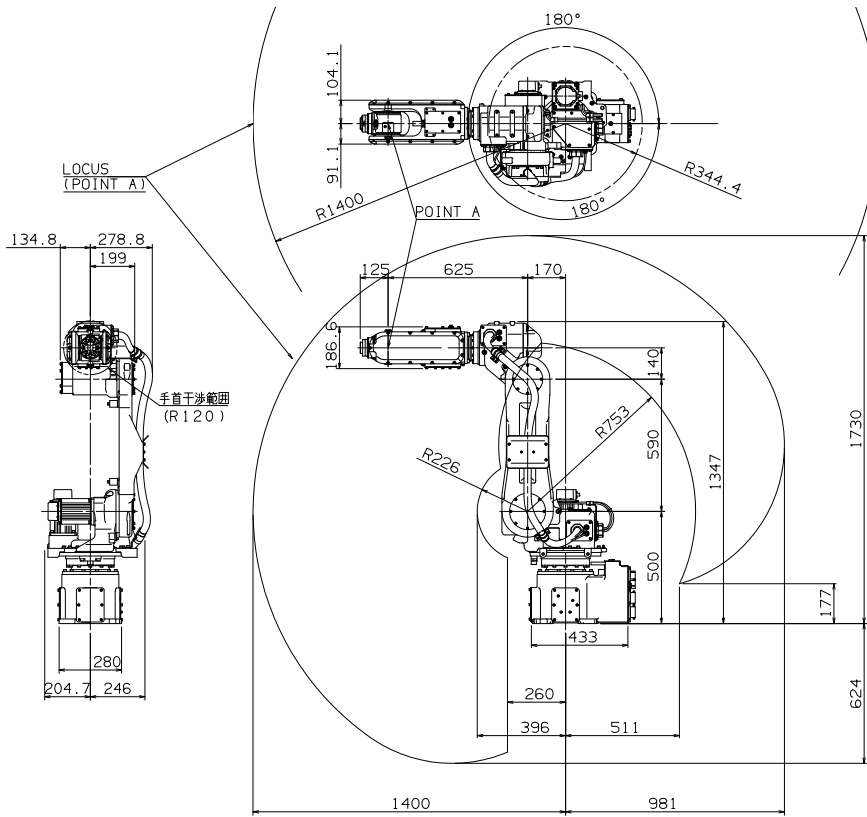

MC12S-01 (wall mount option: OP-S7-010)

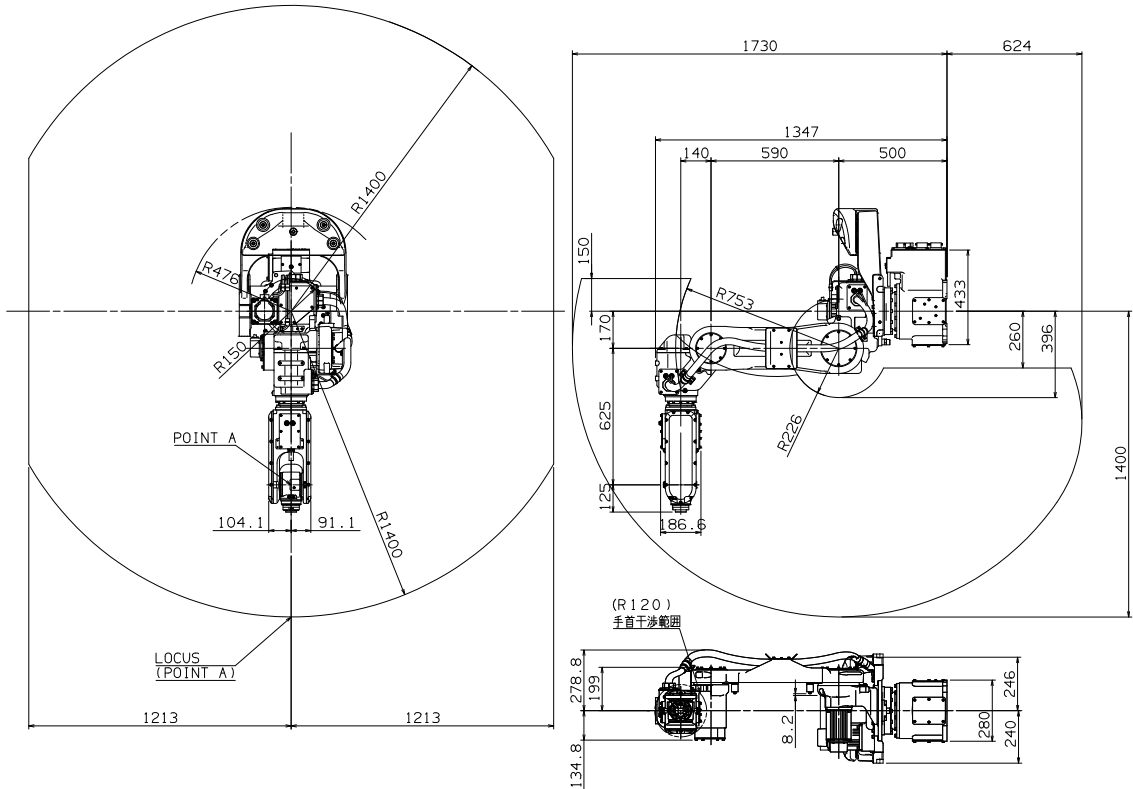

4. Detail of tool mounting plate

For the end effector fixing bolts, use the mounting P.C.D. shown in following figure.

 CAUTION	<p>Don't screw in installation bolts (M6) over thread tap depth. Installation bolts over thread tap depth may damage the wrist.</p>
---	---

MC20-01, MC10L-01, MC12S-01

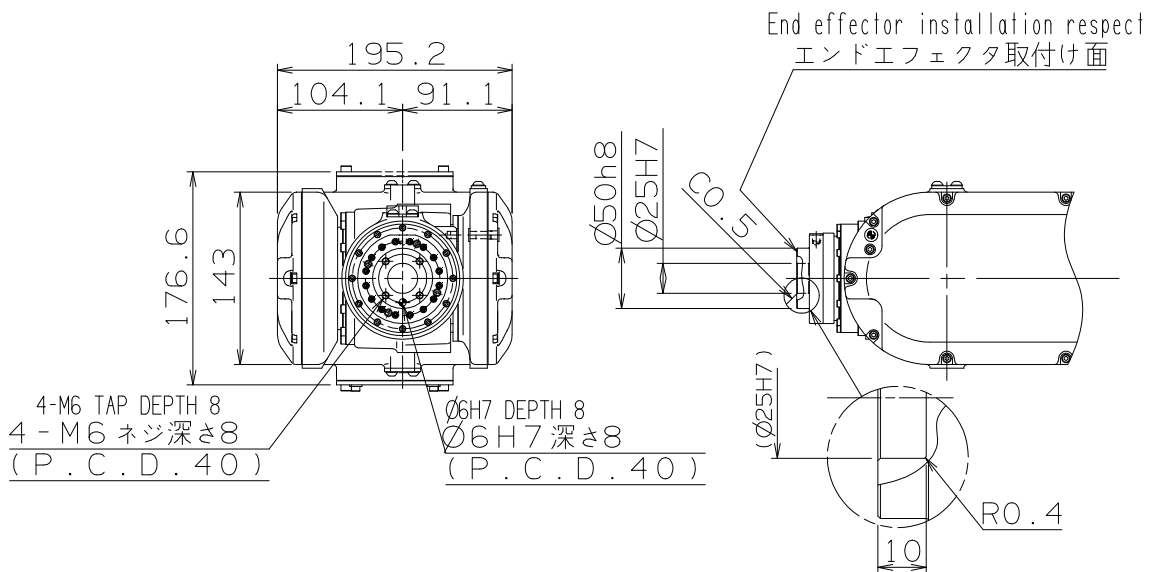

5. Installation Procedure

The installation location and the installation procedure of the robot are critical factors to maintain robot functions. The ambient conditions of installation location not only have influence on the life of mechanical sections of the robot, but also get involved in safety issues. Consequently, strictly observe the environmental conditions shown below. Furthermore, utmost care should be exerted for the installation procedure and the foundation for the robot in order to maintain the robot performance. Strictly observe the installation procedure for the robot provided below.

Installation

To install the robot, give it first priority to thoroughly consider safety of workers and take safety measures. The following describes precautions for this purpose.

Safety measures against entry in the robot operating area

 WARNING	<p>While the robot is in operation, workers are in danger of coming in contact with the robot. To avoid that, install a Safety fence so as to keep the worker away from the robot. Not doing so will cause the workers or other persons to accidentally enter the operating area, thus resulting in accidents.</p>
---	---

■ Installation location and ambient conditions

Conditions (temperature, humidity, height and vibration) are written in “2. Basic Specifications”. Further ambient conditions listed below must be observed.

- (1) Location with the drainage structure so that swivel base is not flooded, when the liquid such as water or cutting fluid is splashed on the robot body
- (2) Location with no flammable or corrosive fluid or gas.
- (3) Type D grounding (the grounding resistance is 100Ω or less) is necessary.

■ Installation procedure

While robot moves, large reaction force is applied to the swiveling base from all directions. Consequently, the robot should be installed in such a manner that the foundation endures reaction force caused by accelerating or decelerating the speed to lock the robot, not to mention that it endures static loads.

Repair uneven spots, cracks, and others on the floor, and then install the robot by following to the table below. If thickness of floor concrete is less than needed level, an independent foundation should be constructed. Inspect the foundation prior to the robot installation, and then construct the foundation, if necessary.



Robot Model	MC20-01, MC10L-01, MC12S-01
Thickness of floor concrete	Not less than 150 mm
Installation parts *1	4 bolts of M16 X 45 (JIS: Strength class 12.9) 4 plain washers of not less than 4.5 mm in thickness and HRC35 in hardness
Tightening torque	287 ± 30 N·m
Allowable repeated tensile *2	Approximately 10,512 N

*1 : Installation parts are not accessory of robot.

*2 : This tensile is per installation bolt when robot is installed with all bolts written in table above.

■ Installation space

To install the robot, fix the swiveling base of the robot.

 WARNING	A mechanical stopper is mounted 4 degrees over the axis 1 working envelope (software limit). When installing a guard fence (safety fence), please make sure to consider the motion range, wrist posture, and the shape of the end effector.
 WARNING	To operate safely, range of the motion can be restricted in axis 1, axis 2 and axis 3 (Option). Because the option parts are always necessary to restrict the motion range, do not move the standard parts (mechanical stopper block etc.) alone.

MC20-01

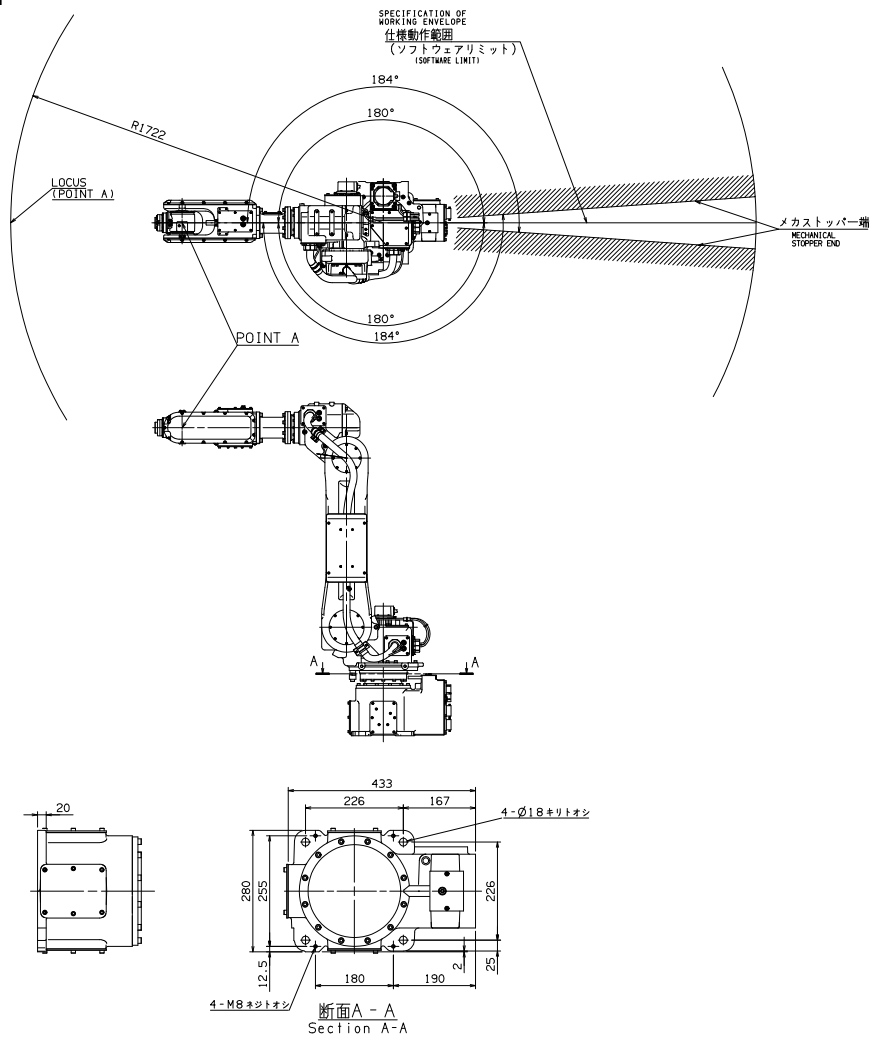

MC10L-01

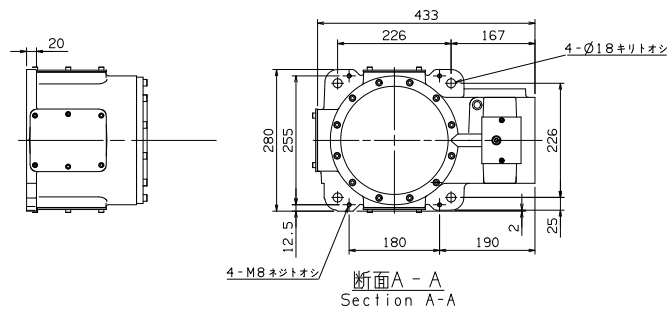
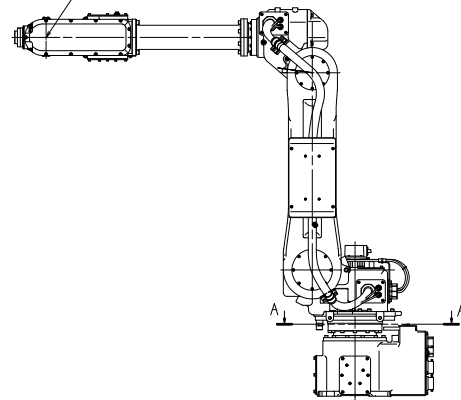
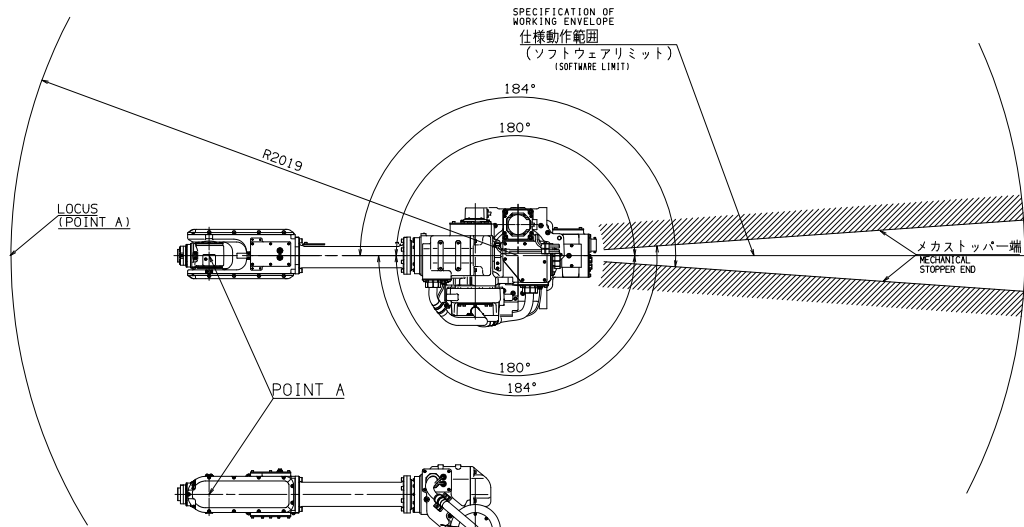

MC12S-01

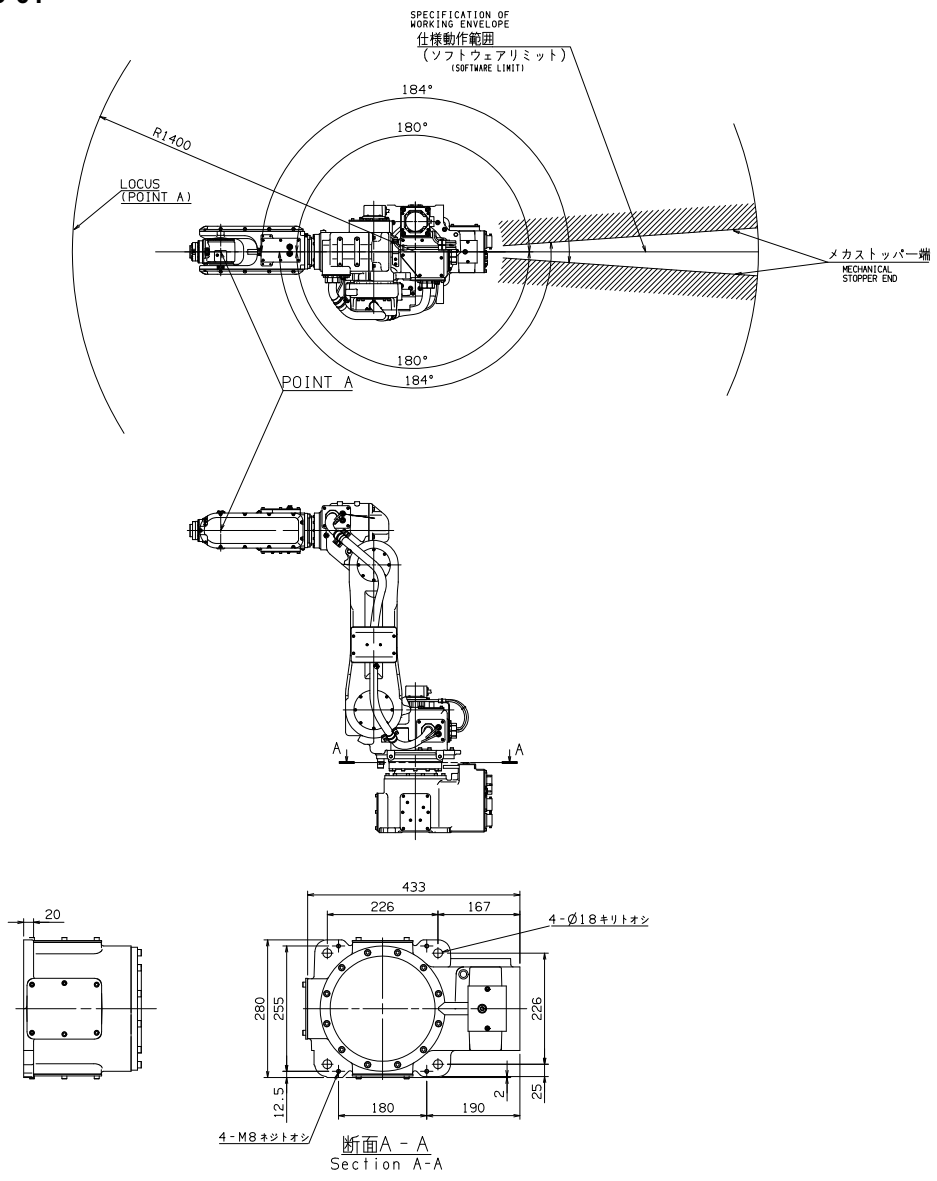

■ Accuracy of installation surface

When installing robot, strictly observe precautions listed below to cause no deformation in the swivel base.

- (1) Make the deviation from the flatness of the 4 plates on the robot installation surface fall within 0.5 mm.
- (2) Make the deviation in height between the 4 places of each base plate installation surface and the robot installation surface fall in the range of 0.5 mm (± 0.25 mm).

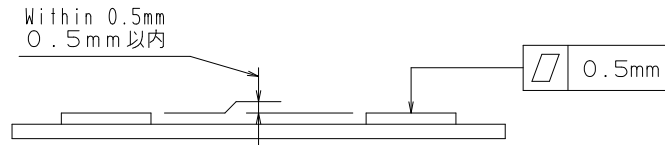

- (3) If the two precautions above cannot be observed, use jack bolts to bring the four places into even contact with the installation surface.

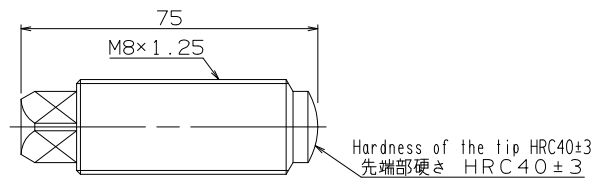

■ Maximum Robot Generative Force

Robot type	Maximum vertical generative force FV	Maximum horizontal generative force FH	Maximum Vertical generative moment MV	Maximum horizontal generative moment MH
MC20-01 MC10L-01 MC12S-01	8,300 N	6,000 N	9,400 N·m	8,100 N·m

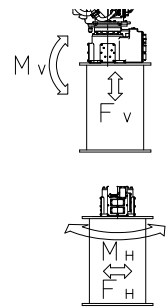

6. Maximum wrist load

 CAUTION	<p>Load fixed on the tip of wrist is regulated by “allowable payload mass”, “allowable static load torque”, and “allowable moment of inertia”. Strictly keep the wrist load within each allowable value. If wrist load exceeds the allowable value, this robot is out of guarantee.</p> <p>Refer to the table of “2 Basic specifications” and following figures for the detail of each specification.</p>
---	---

■ Torque map

C.O.G. of wrist load should exist inside the range shown below.

MC20-01

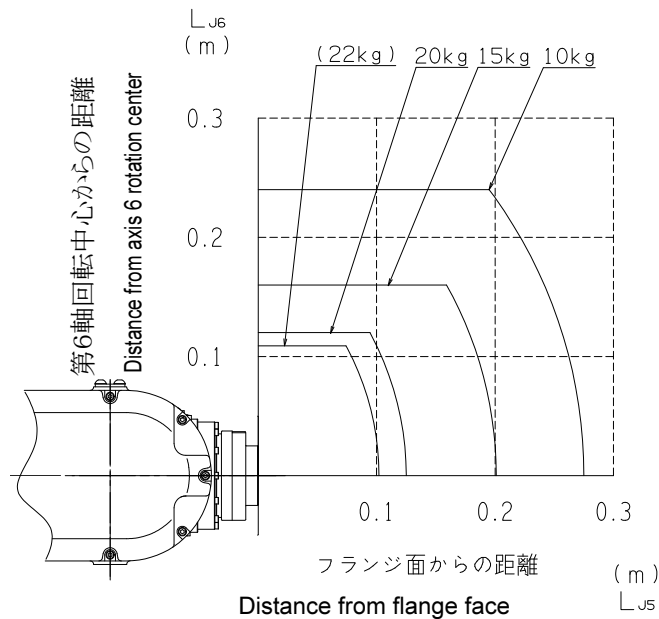

MC10L-01

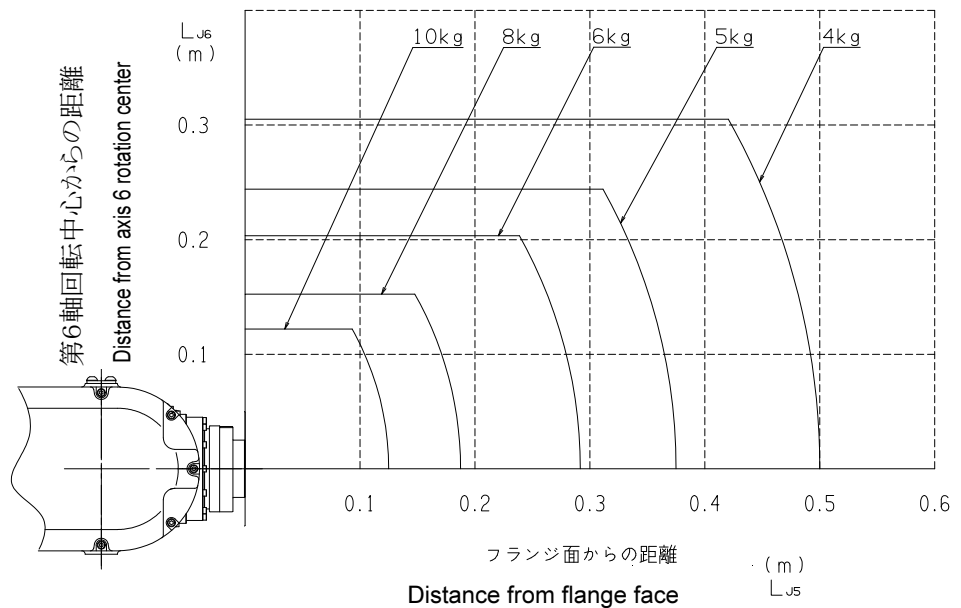

MC12S-01

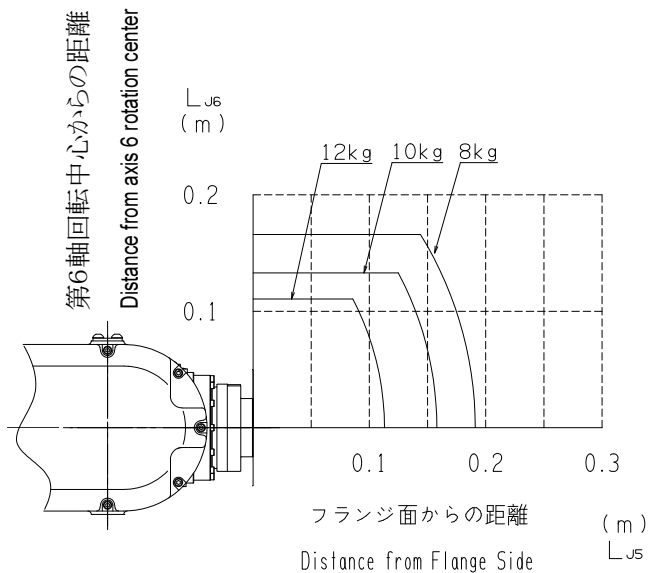

■ Wrist axis load conditions

Static load torque and moment of inertia of wrist load should exist inside the range shown below.

MC20-01

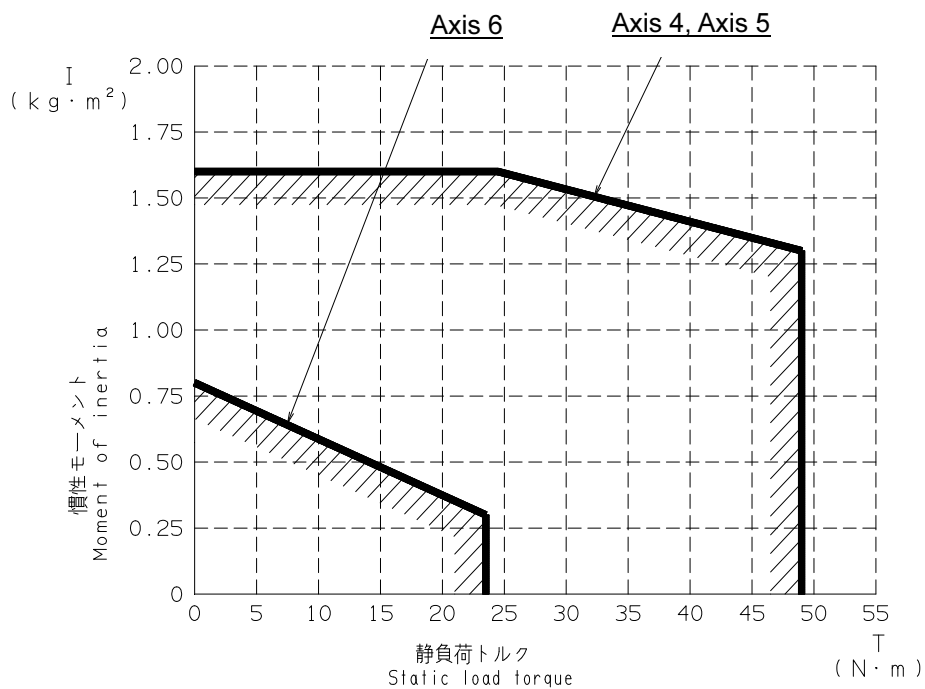

MC10L-01

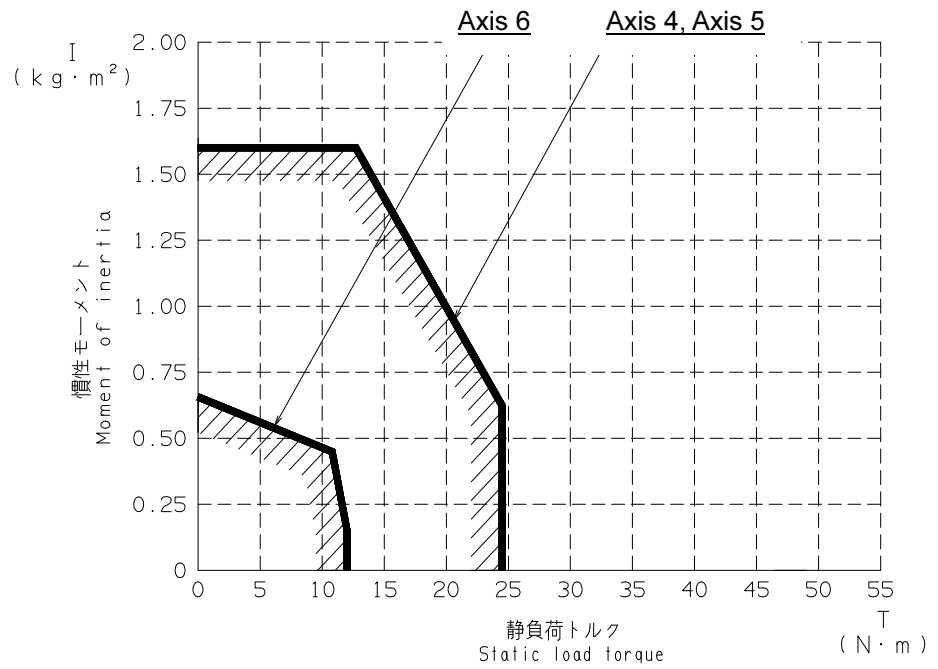

MC12S-01

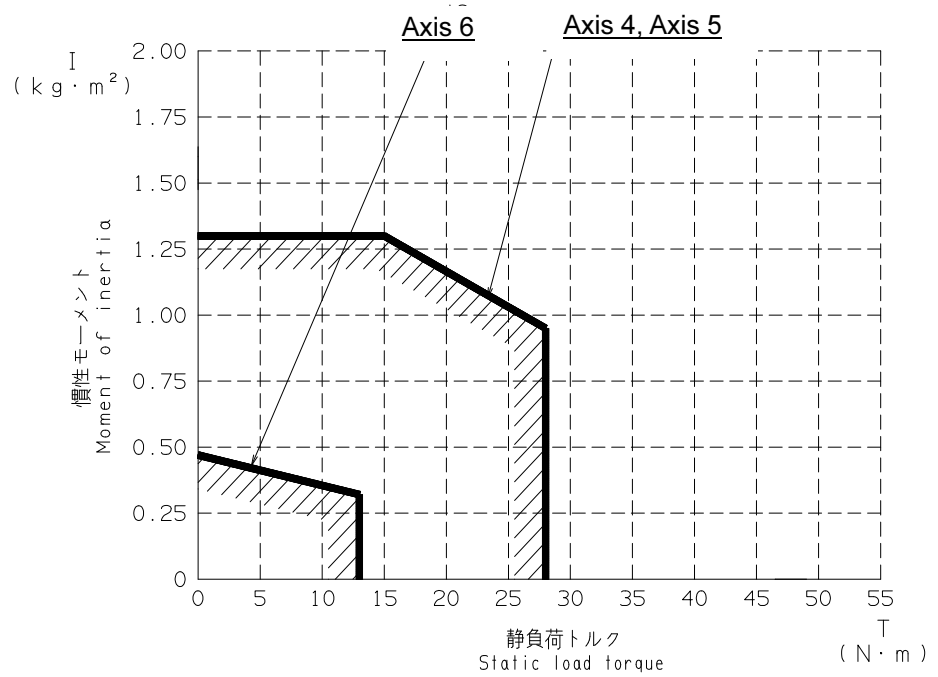

■ How to calculate inertia moment of wrist axes

The method of calculating the inertia moment around a general each axis is shown below.

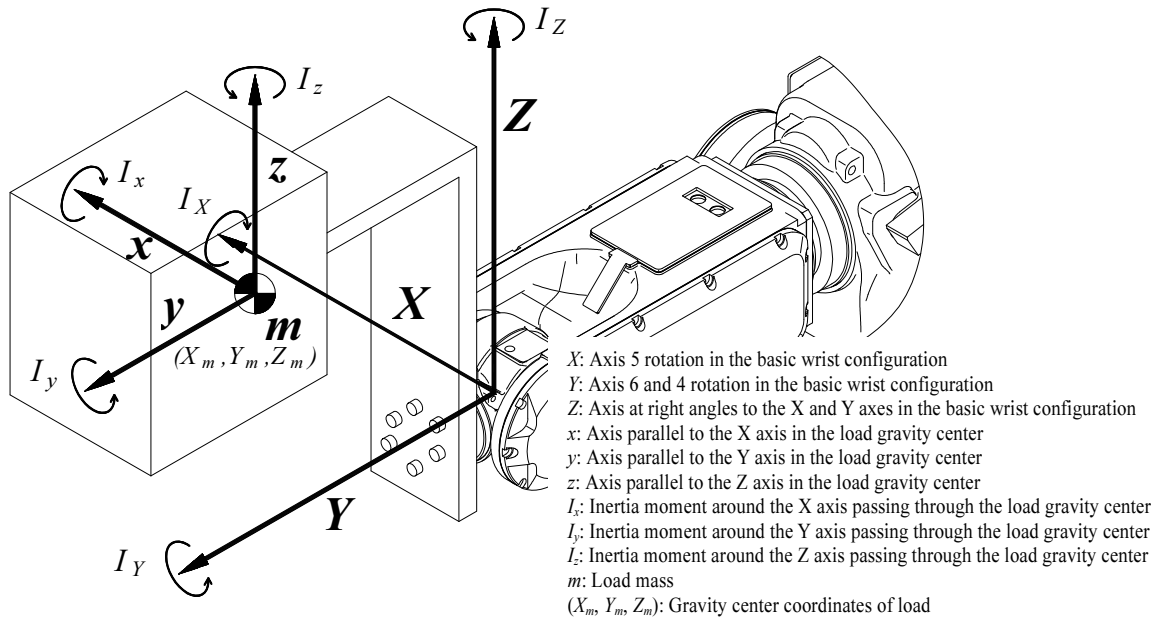

1. Inertia moment around axis 6

The inertia moment around axis 6 becomes the following expressions.

$$I_{J6} = I_Y = m \cdot (X_m^2 + Z_m^2) + I_y$$

2. Inertia moment around axis 4 and 5

The value changes into the inertia moment around axis 4 and 5 depending on the posture of axis 6. The maximum value around *X* axis and *Z* axis in above figure is assumed to be an inertia moment.

$$I_{J4J5} = \max (I_X , I_Z)$$

$$\therefore I_X = m \cdot (Y_m^2 + Z_m^2) + I_x$$

$$\therefore I_Z = m \cdot (X_m^2 + Y_m^2) + I_x$$

7. Option specifications

○: Possible to correspond / -: Impossible to correspond

No	Item	Specifications	Parts No.	Robot type		
				MC20-01	MC10L-01	MC12S-01
1	Parts for installation *4	Chemical anchor specification (Installing plate with 4 base plates + chemical anchor bolts)	OP-F1-019	○	○	○
		Ore anchor specification (Installing plate with 4 base plates + ore anchor bolts)	OP-F2-015	○	○	○
		Robot installation bolts and washers	OPJ-F1-0051	○	○	○
2	Axis 1 adjustable stopper *4	Restriction of axis 1 operation edge (± 3.14 ± 0.52 rad, every 0.17 rad)	OP-S5-015	○	○	○
3	Axis 2 adjustable stopper *4	Restriction of axis 2 operation edge (+ 2.62 ~ + 1.83, - 0.39 ~ - 1.04 rad, every 0.39 rad)	OP-A5-019	○	○	○
4	Axis 3 adjustable stopper *4	Restriction of axis 3 operation edge (+ 3.14 ~ + 2.35, - 1.43 ~ + 0.64 rad, every 0.39 rad)	OP-A6-016	○	○	○
5	Solenoid valve plate *1	For storage in wrist of solenoid valve *1	OP-H1-018	○	○	○
6	Solenoid valve inside arm *2	(table below)		○	○	○
7	Zeroing pin & Zeroing block *4	Zeroing pin & Zeroing block	OP-T2-047	○	○	○
8	Hanging jig	Jig for installation of ceiling mount robot	OP-S7-007	○	○	○
9	Wall mount option	Necessary for wall mount specification	OP-S7-010	-	-	○
10	Hanging jig for wall mount	Jig for installation of wall mount robot (This is necessary when "wall mount option" is selected)	OP-S7-011	-	-	○
11	Assembly jig	Jig for assembling option parts	OP-TY-004	○	○	○
12	Name seal for ceiling mount	Name seal for MC20-01 ceiling mount	OP-N2-019	○	-	-
		Name seal for MC10L-01 ceiling mount	OP-N2-022	-	○	-
		Name seal for MC12S-01 ceiling mount	OP-N2-027	-	-	○
13	Encoder ID writing cable		MR20-OP03-A	○	○	○
14	Bypass cable unit *4		BCUNIT20-50	○	○	○
15	Water proof coolant Paint	Water proof coolant paint for MC20-01	OP-N5-016	○	-	-
		Water proof coolant paint for MC10L-01	OP-N5-020	-	○	-
		Water proof coolant paint for MC12S-01	OP-N5-021	-	-	○

*1; This is the unit of storage plate and cover. Solenoid valve and wires are not included.
Applicable solenoid valve size is two SY3000 (SMC) valves or one SY5000 (SMC) valve. When solenoid valve is installed inside, exhaust air must be exhausted to the outside of the robot (not inside).

*2; Detail of "Solenoid valve inside arm"

	Specifications	Parts No.
1	2 Double solenoids + Application cable	CABLEMR-DD-A + OPJ-H1-0008
2	2 Double solenoids	CABLEMR-DD + OPJ-H1-0008
3	1 Double solenoid + Application cable	CABLEMR-D-A + OPJ-H1-0010
4	1 Double solenoid	CABLEMR-D + OPJ-H1-0010
5	2 Single solenoids + Application cable	CABLEMR-SS-A + OPJ-H1-0009
6	2 Single solenoids	CABLEMR-SS + OPJ-H1-0009
7	1 Single solenoid + Application cable	CABLEMR-S-A + OPJ-H1-0011
8	1 Single solenoid	CABLEMR-S + OPJ-H1-0011
9	1 Double solenoid + 1 Single solenoid + Application cable	CABLEMR-DS-A + OPJ-H1-0012
10	1 Double solenoid + 1 Single solenoid	CABLEMR-DS + OPJ-H1-0012

Single solenoid valve type SYJ3130-5GS [SMC]

Double solenoid valve type SYJ3230-5GS [SMC]

*3; Transporting jig is accessory as standard. If another transporting jig is needed to transport the robot, please order KP-ZJ-005 (although not written in above list) to Nachi service.

*4; These parts are packed separately from the robot. (Not attached on the robot)

8. Application wiring and tubing diagram (standard)

■ Wiring and tubing system diagram

MC20-01, MC10L-01, MC12S-01

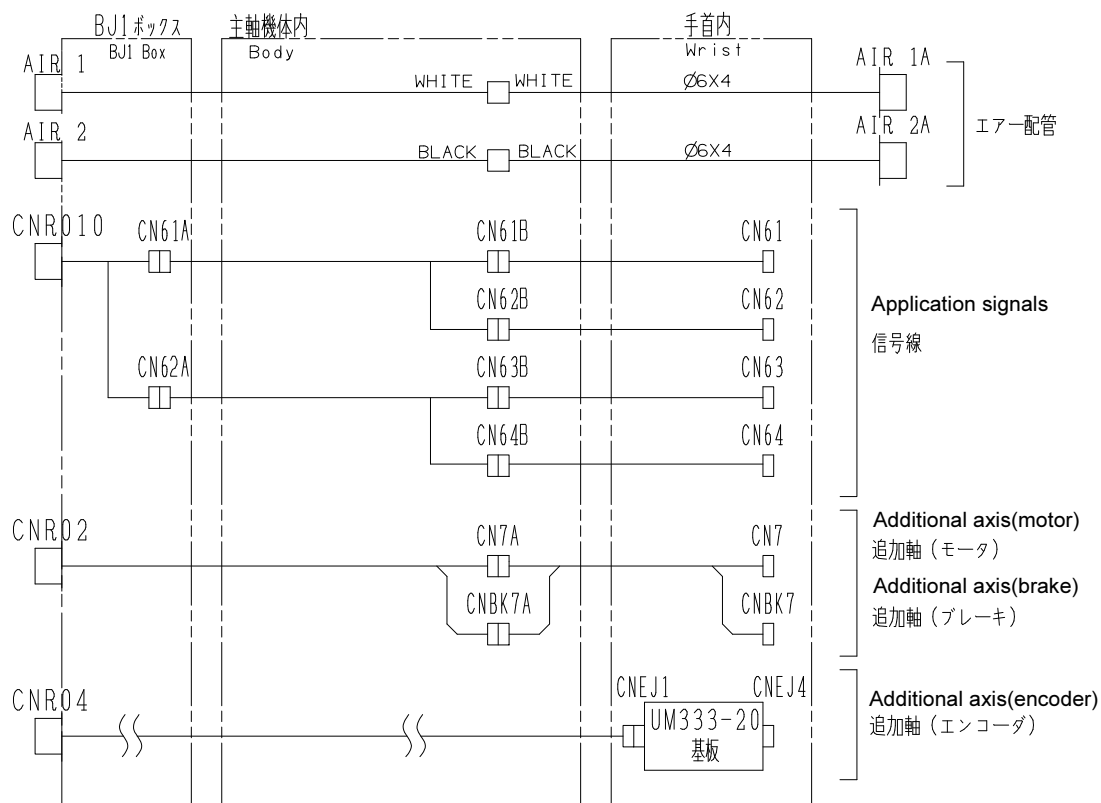

For additional axis encoder, it is necessary to use a bus-connection type encoder that is designated by NACHI. For more details, please contact our technical department.

■ Detailed diagram of the base frame



- When not using air, attach plugs to the air in/out holes so that water or oil can not get into the robot arm. (The plugs are attached when the robot is shipped)
- When attaching air valves or cable brackets etc., please use "Tap holes for application (4-M5)" shown in the figure. Tightening those things with the cover fixing bolts or making holes on the box cover itself may cause water leakage or oil leakage into the arm and the parts of the robot may be damaged.

MC20-01, MC10L-01, MC12S-01

6-M5 x 10
(締付トルク: 4.0Nm)

Fasten torque

配線BOXカバー

Cover of cable joint box

2-エア-出口 (φ6チューブ用)

2-Air Out (For φ6 tube)

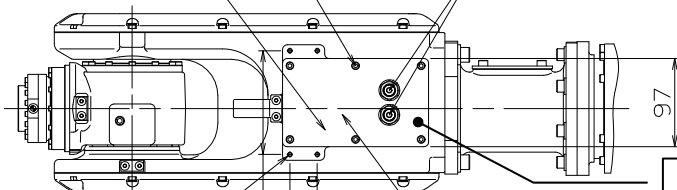

4-M5 深さ10
アプリケーション
取付タップ

Tap holes for application

アプリケーション線
動力線、エンコーダ線

Application, power, encoder cable

The application signal lines are in the box.
When using those, make a hole on the cover and attach a cable clamp.
The cable clamp must be waterproof type.

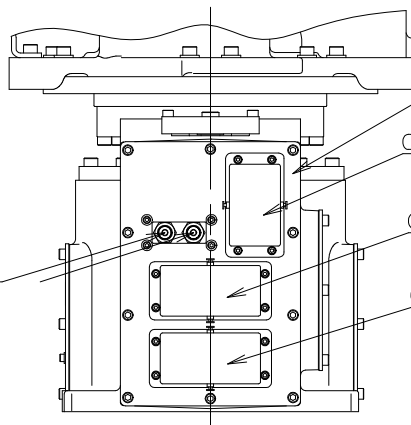
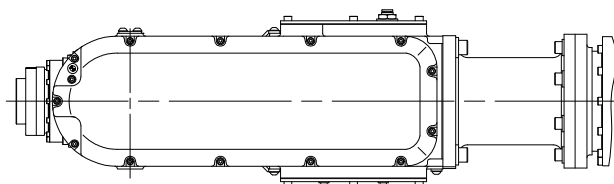

BJ1パネル
BJ1 Panel

CNR04

CNR02

CNR010

2-エア-入口
(Rc1/4)
2-Air Inlet
(Rc1/4)

■ Detailed diagram of the connectors

MC20-01, MC10L-01, MC12S-01

1. BJ1 side (connector)

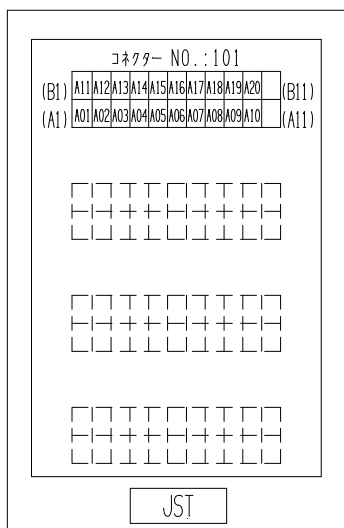

Connector for application cable

Wire-side shell: JFM-WSA-4-A (JST)
or JFM-WSA-4-C(JST)

Guide plate A kit: FM-GPAK-4 (JST)

Receptacle housing: JFM2FDN-22V-K (JST)

Receptacle contact:

- (a) SJ2F-01GF-P1.0 (JST) (0.20 ~ 0.50 mm²)
- (b) SJ2F-21GF-P1.0 (JST) (0.30 ~ 0.75 mm²)

Manual crimp tool:

- for (a), YRS-8861
- for (b), YRF-1120

Cable diameter suitable for wire-side shell:

- JFM-WSA-4-A (JST) $\phi 26.2 \sim \phi 28.0$
- JFM-WSA-4-C (JST) $\phi 15.5 \sim \phi 16.5$

(This figure is drawn seeing from the backside of the robot.)

2. BJ3 side (junction connector)

CN61, CN62, CN63

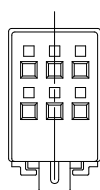
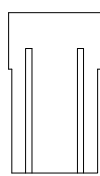

CN64

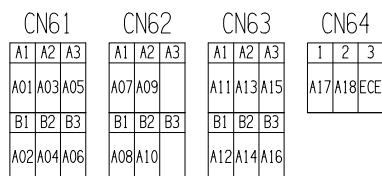
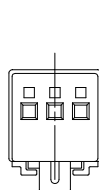
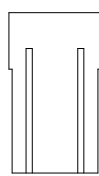

Connector form (CN61, CN62 and CN63)

Housing: J21DF-06V-KX (JST)

Partner connector

Housing: J21DPM-06-KX (JST)

Contact:

- (a) SJ2M-01GF-M1.0N (0.20 ~ 0.50 mm²)
- (b) SJ2M-21GF-M1.0N (0.30 ~ 0.75 mm²)
- (c) SJ2M-01GF-M1.0S (0.20 ~ 0.50 mm²)

Manual crimp tool: (one of a,b or c)

- for (a)(c), YRS-8861
- for (b), YRF-1120

Connector form (CN64)

Housing: J21SF-03V-KX (JST)

Partner connector

Housing: J21SPM-03V-KX (JST)

- (a) SJ2M-01GF-M1.0N (0.20 ~ 0.50 mm²)
- (b) SJ2M-21GF-M1.0N (0.30 ~ 0.75 mm²)
- (c) SJ2M-01GF-M1.0S (0.20 ~ 0.50 mm²)

Manual crimp tool: (one of a,b or c)



- for (a)(c), YRS-8861
- for (b),: YRF-1120

(This figure is drawn seeing from the backside of the robot.)

9. Transport procedure

Safety measures against transport

The following describes precautions for transporting the robot. Fully understand the precautions for safe transport work.

 WARNING	The robot must be transported by personnel who have licenses required for slinging work, crane operation, forklift truck operation, and others.
 WARNING	To lift the robot or the controller, follow the procedures specified in the Maintenance Manual. Following any procedures other than those specified will cause the robot to topple over or drop during transport, thus resulting in accidents.
 CAUTION	During transport or installation work of the robot, pay utmost care not to cause damage to wirings. Furthermore, after installing the robot, take protective measures such as using protective guards so that the wirings will not be damaged by workers or other persons, or forklift trucks or else.

To transport the robot, make it a rule to use a crane.

First, put the robot into the configuration shown below and mount the two carrier brackets dedicated to the transport of the robot to both sides of the robot frame. Then, lift the robot using four hanging wires. Fix these dedicated brackets with the two M12 X 30 bolts. The tightening torque is 116 N·m. Recommended length of the hanging wires is 3 m.

In case that wall mount option is selected, wall mount hanging jig (OP-S7-011) has to be used instead of the hanging jig (accessory when shipped) with using two M12x85 bolts and two M12x120 bolts.

MC20-01

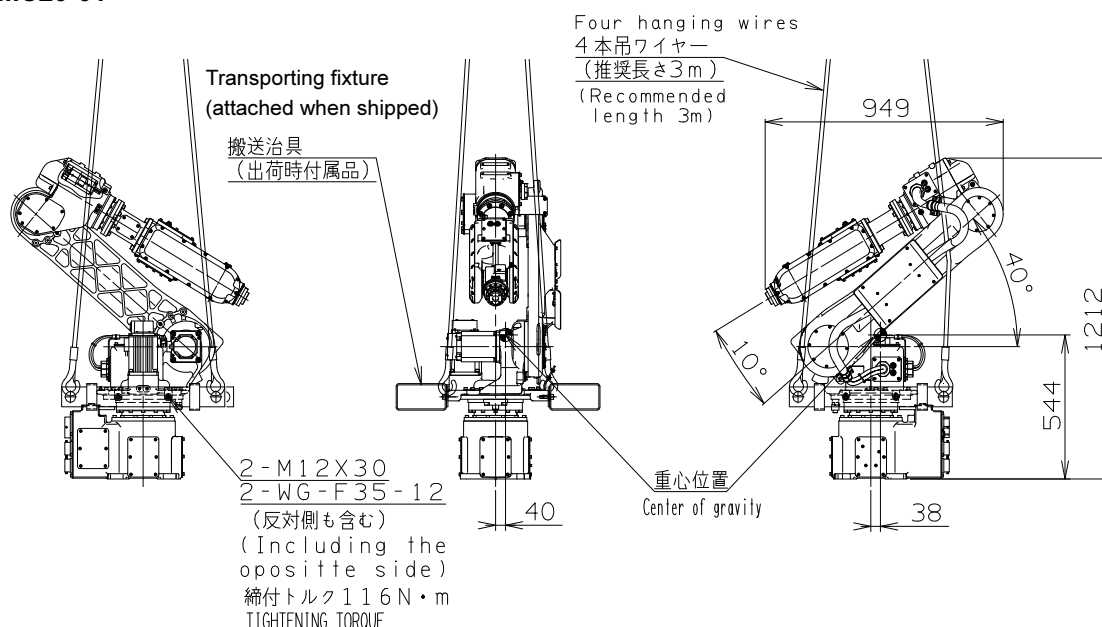

MC10L-01

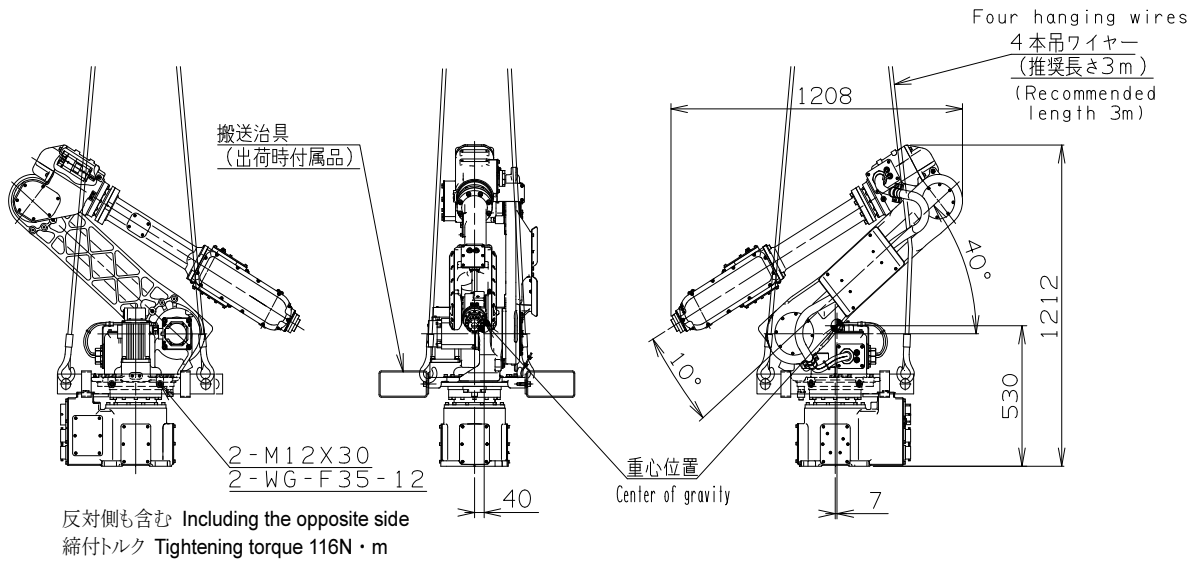

MC12S-01

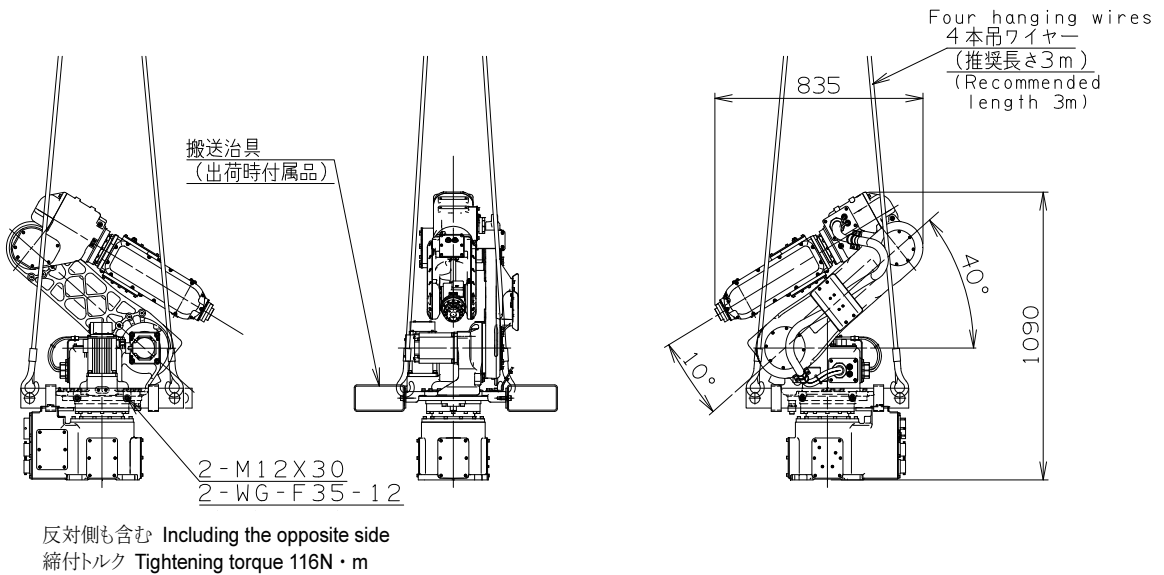

MC12S-01 (wall mount option: OP-S7-010)

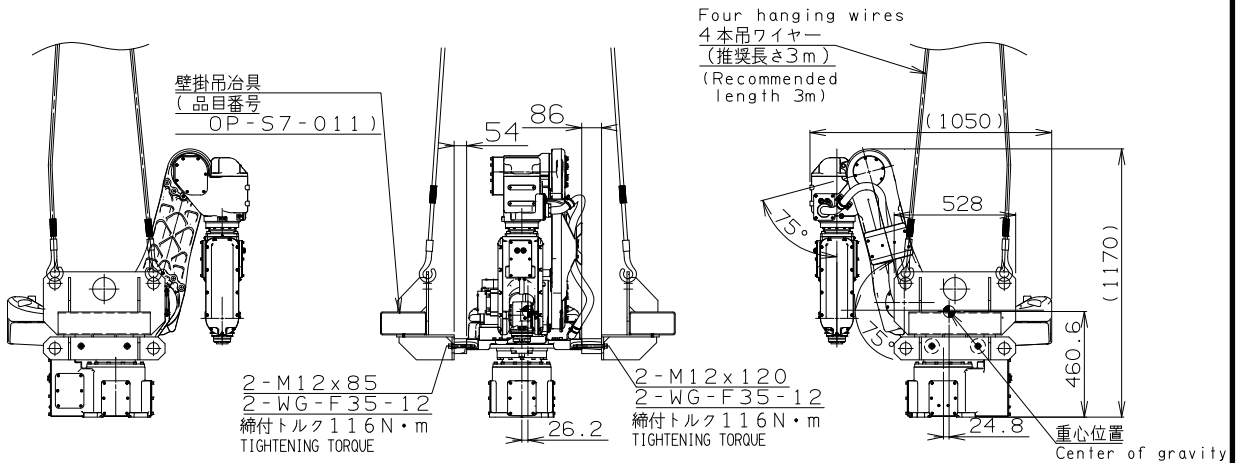

10. Installation (specification which contains a robot)

1. Delivery condition

Because the expense is different, which form to choose be sufficiently examined.

Style	Condition	Details
1	Delivery on the truck	Robot is delivered on the truck near the entrance of customer's plant.
2	Delivery after installation and test-run	Robot is installed and test-run done.
3	Delivery after installation and test-run with work piece	After style 2, teaching with work piece is done.

2. Operation and maintenance education

The special spot operation guide and the special spot preservation guide are the outside of the estimation. Also, there is schooling system in the Toyama factory, too.

Consult with each NACHI-FUJIKOSHI office for the details.

3. The type D grounding (the grounding resistance is 100Ω or less) is necessary.

11. Consuming power (Robot + Controller)

1.7 kVA (peak)

12. Paint color

Standard color	Controller cabinet	Munsell 10GY9/1
	Robot body	Munsell 10GY9/1

Water proof coolant paint option is useful for the circumstance such as that coolant splashes on robot body. Please refer to "7 Option specifications" for the type of this option.

13. Warranty

Elapse of 1 year after delivery.

The specifications and appearances in this document might change without a previous notice for the improvement.

NACHI NACHI-FUJIKOSHI CORP.		http://www.nachi-fujikoshi.co.jp/	
JAPAN MAIN OFFICE	Phone: +81-3-5568-5245	Fax: +81-3-5568-5236	Shiodome Sumitomo Bldg. 17F, 1-9-2 Higashi-Shinbashi Minato-ku, TOKYO, 105-0021 JAPAN
NACHI NORTH AMERICA		http://www.nachirobotics.com/	
North America Headquarters	Phone: 248-305-6545	Fax: 248-305-6542	22285 Roethel Drive, Novi, Michigan 48375 U.S.A.
Greenville Service Office	Use 248-305-6545	Use 248-305-6542	South Carolina, U.S.A.
San Antonio Service Office	Use 248-305-6545	Use 248-305-6542	Texas, U.S.A.
Kentucky Branch Office	Phone: 502-695-4816	Fax: 502-695-4818	116 Collision Center Drive, Suite A, Frankfort, KY 40601 U.S.A
Training Office	Phone: 248-334-8250	Fax: 248-334-8270	22213 Roethel Drive, Novi, Michigan 48375 U.S.A.
Toronto Branch Office	Phone: 905-760-9542	Fax: 905-760-9477	89 Courtland Avenue, Unit 2, Vaughan, Ontario L4K3T4 CANADA
Mexico Branch Office	Phone : +52-555312-6556	Fax: +52-55-5312-7248	Urbina # 54, Parque Industrial Naucalpan, Naucalpan de Juarez, 53370, Estado de México, MEXICO
Saltillo Service Office	Phone : +52-844416-8053	Fax: +52-844416-8053	Canada 544 Privada Luxemburgo C. P. 25230, Saltillo, Coahuila, MEXICO
NACHI ROBOTIC EUROPE		http://www.nachi.de/	
Germany			
Nachi Europe GmbH	Phone: +49-(0)2151-65046-0	Fax: +49-(0)2151-65046-90	Bischofstrasse 99, 47809, Krefeld, GERMANY
United Kingdom		http://www.nachi.co.uk/	
Nachi U.K. LTD.	Phone: +44-(0)121-250-1895	Fax: +44-(0)121-250-1899	Unit 7, Junction Six Industrial Estate, Electric Avenue, Birmingham B6 7JJ, U.K.
Czech Republic			
Nachi Europe	Phone: + 420-255-734-000	Fax: +420-255-734-001	Prague 9, VGP Park, Czech republic
NACHI ROBOTIC ASIA		http://www.nachi-korea.co.kr/	
Korea			
Korea	Phone: +82-(0)2-469-2254	Fax: +82-(0)2-469-2264	2F Dongsan Bldg. 276-4, Sungsu 2GA-3DONG, Sungdong-ku, Seoul 133-123, KOREA

Copyright NACHI-FUJIKOSHI CORP.

Robot Division

1-1-1, FUJIKOSHIHONMACHI, TOYAMA CITY, JAPAN 930-8511
Phone +81-76-423-5137
Fax +81-76-493-5252

NACHI-FUJIKOSHI CORP. holds all rights of this document. No part of this manual may be photocopied or reproduced in any form without prior written consent from NACHI-FUJIKOSHI CORP. Contents of this document may be modified without notice. Any missing page or erratic pagination in this document will be replaced.

In case that an end user uses this product for military purpose or production of weapon, this product may be liable for the subject of export restriction stipulated in the Foreign Exchange and Foreign Trade Control Law. Please go through careful investigation and necessary formalities for export.

Original manual is written in Japanese.

NACHI-FUJIKOSHI CORP. ©