

NACHI

Standard specifications

SRA100J-01-FD11

1st edition

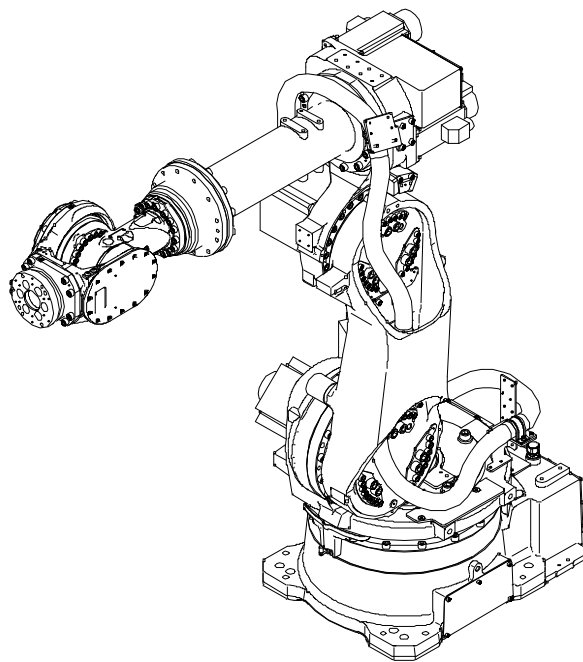

NACHI-FUJIKOSHI CORP.

1306, SSRAEN-051-001,001

Table of contents

1. Outline.....	1
2. Basic specifications.....	2
3. Robot dimensions and working envelope.....	3
4. Details of load mounting face.....	4
5. Installation procedure.....	5
6. Allowable wrist load.....	8
7. Option specifications.....	11
8. Application wiring and piping diagram.....	12
9. Transport procedure.....	14
10. Delivery style (specification which contains a robot).....	16
11. Consuming power (Robot + Controller).....	16
12. Paint color.....	16
13. Warranty.....	16

1. Outline

“NACHI ROBOT” has used mechatronic techniques, cultivated throughout the last few decades, to supply robots suited for industries utilizing welding and the material handling techniques.

“SRA100J” is a robot of simple highly rigid structure which is optimal for spot welding, material handling and other, applications.

Standard type	
	Max. payload 100 kg
Floor mount	SRA100J-01

1. Due to the compact body, high- density installation is possible.
2. Because the height of the robot is small, a multi-layer installation with other robots is possible.
3. This robot features a powerful wrist that can support a large tool.
4. Due to a wide operation area, it is possible to use for various production process.
5. This robot features the largest wrist bend angle in its class due to the slim compact wrist. The reduction of restriction due to wrist operation opens the robot to more diverse applications.
6. The required installation area has been reduced by routing water, air and cables through the swivel base for spot application.

2. Basic specifications

Item		Specifications
Robot model		SRA100J-01
Construction		Articulated
Number of axis		6
Drive system		AC servo motor
Max. working envelope	Axis 1	± 3.14 rad ($\pm 180^\circ$)
	Axis 2	$-2.09 \sim +1.05$ rad ($-120 \sim +60^\circ$)
	Axis 3	$+1.57 \sim -2.18$ rad ($+90 \sim -125^\circ$)
	Axis 4	± 6.28 rad ($\pm 360^\circ$)
	Axis 5	± 2.36 rad ($\pm 135^\circ$)
	Axis 6	± 6.28 rad ($\pm 360^\circ$)
Max. speed	Axis 1	2.37 rad /s ($\pm 136^\circ$ /s)
	Axis 2	2.01 rad /s (115° /s)
	Axis 3	2.79 rad /s (160° /s)
	Axis 4	4.19 rad /s ($\pm 240^\circ$ /s)
	Axis 5	4.07 rad /s ($\pm 233^\circ$ /s)
	Axis 6	6.13 rad /s ($\pm 351^\circ$ /s)
Max. pay load	Wrist	100 kg
	Forearm *1	25 kg (45 kg at maximum)
Allowable static load torque	Axis 4	580 N·m
	Axis 5	580 N·m
	Axis 6	290 N·m
Allowable moment of inertia *2	Axis 4	45 kg·m ²
	Axis 5	45 kg·m ²
	Axis 6	22.7 kg·m ²
Position repeatability *3		± 0.1 mm
Installation		Floor mounting
Ambient conditions		Temperature: 0 to 45 °C *4 Humidity: 20 to 85%RH (No dew condensation allowed) Vibration to the installation face: Not more than 0.5G (4.9 m/s ²)
Noise *5		78.1 dB
Robot mass		670 kg

1[rad] = $180/\pi$ [°], 1[N·m] = 1/9.8[kgf·m]

- On controller display, axis 1 to 6 is displayed as J1 to J6 for each.

- The specification and externals described in this specification might change without a previous notice for the improvement.

- Explosion-proof is not available.

*1: This value changes by placement and load conditions of a wrist.

*2: The Allowable moment of inertia of a wrist changes with load conditions of a wrist.

*3: This value conforms to "JIS B 8432".

*4: Permitted height is not higher than 1,000m above sea level. If used in higher place, permitted temperature is affected by height.

*5: Robot noise is A-weighted equivalent sound level measured under "JIS Z 8737-1" (ISO 11201) with max. payload and max. speed.

3. Robot dimensions and working envelope

[SRA100J-01]

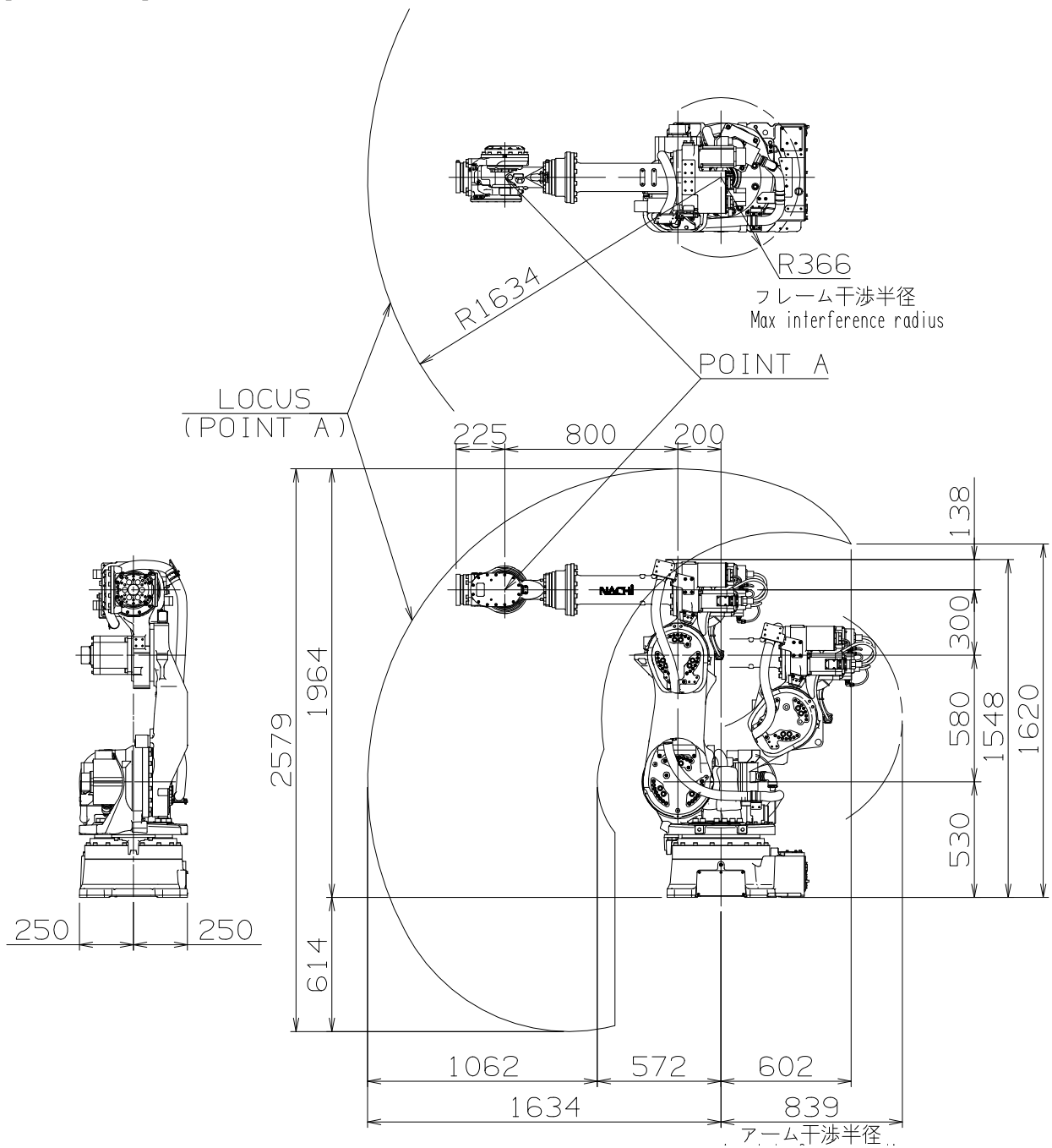

4. Details of load mounting face

■ Wrist

For the end effector fixing bolts, use the mounting P.C.D. shown in the following figures. Besides the mounting P.C.D., different P.C.D. (option) is available. For details, contact our service division.



Be sure to screw the M10 tool fixing bolts in the wrist not deeper than the screw depth in the mounting face. Screwing the bolts deeper than the screw depth may damage the wrist.

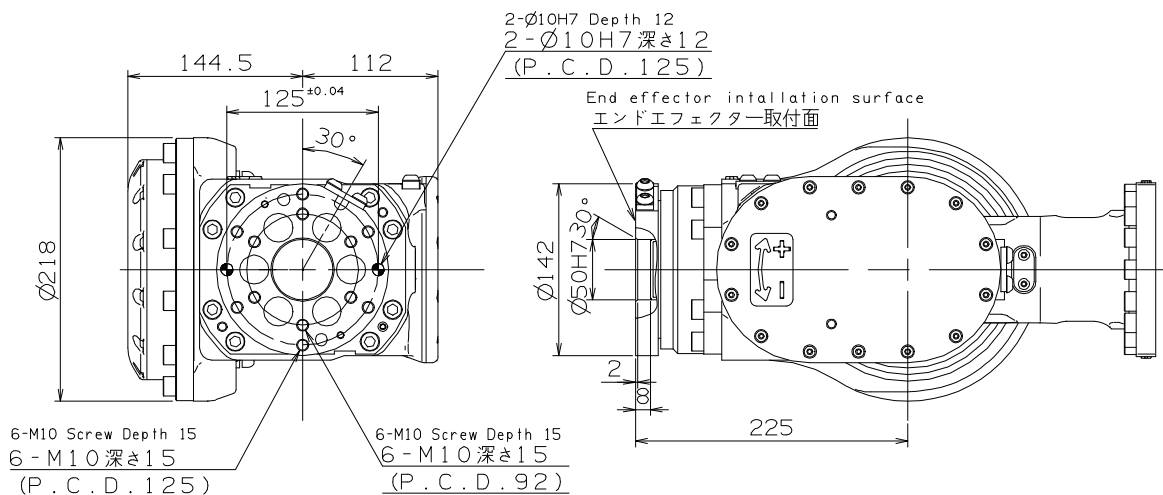

■ Upper part of forearm

Ancillary equipments can be mounted to the upper part of robot forearm.

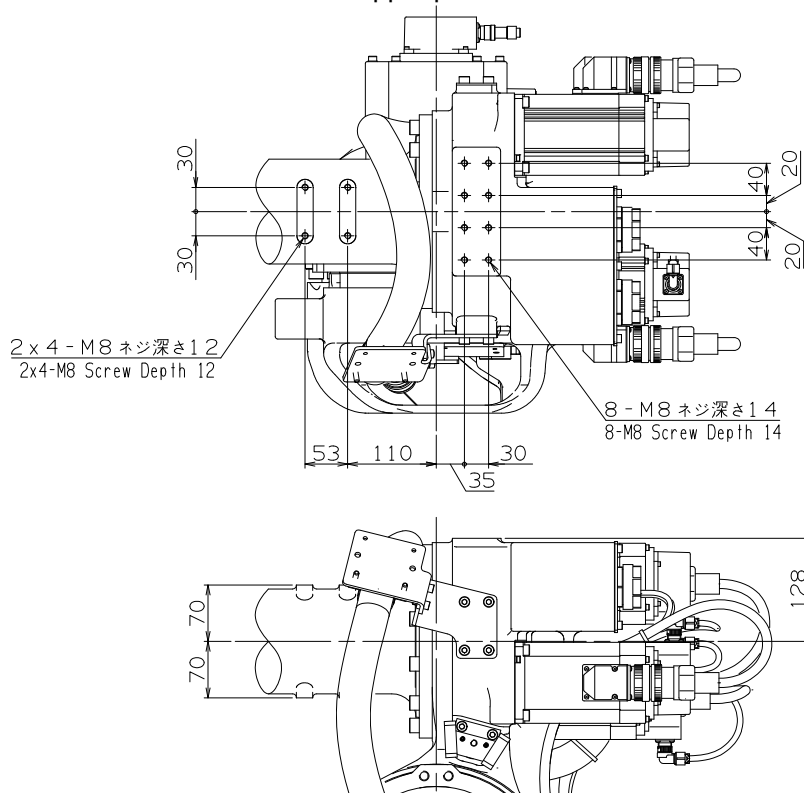

5. Installation procedure

The installation location and the installation procedure of the robot are critical factors to maintain robot functions. The ambient conditions of installation location not only have influence on the life of mechanical sections of the robot, but also get involved in safety issues. Consequently, strictly observe the environmental conditions shown below. Furthermore, utmost care should be exerted for the installation procedure and the foundation for the robot in order to maintain the robot performance. Strictly observe the installation procedure for the robot provided below.

Installation

To install the robot, give it first priority to thoroughly consider safety of workers and take safety measures. The following describes precautions for this purpose.

Safety measures against entry in the robot operating area

 <p>WARNING</p>	<p>While the robot is in operation, workers are in danger of coming in contact with the robot. To avoid that, install a Safety fence so as to keep the worker away from the robot. Not doing so will cause the workers or other persons to accidentally enter the operating area, thus resulting in accidents.</p>
--	---

■ Installation location and ambient conditions

Conditions (temperature, humidity, height and vibration) are written in “2. Basic Specifications”. Further ambient conditions listed below must be observed.

- (1) Location with the drainage structure so that swivel base is not flooded, when the liquid such as water or cutting fluid is splashed on the robot body
- (2) Location with no flammable or corrosive fluid or gas.
- (3) Type D grounding (the grounding resistance is 100Ω or less) is necessary.

■ Installation procedure



While robot moves, large reaction force is applied to the swiveling base from all directions. Consequently, the robot should be installed in such a manner that the foundation endures reaction force caused by accelerating or decelerating the speed to lock the robot, not to mention that it endures static loads.

To install the robot on the floor, if the floor concrete is not less than 150 mm in thickness, repair uneven spots, cracks, and others on the floor, and then install the robot with the use of 8 bolts (option) of M20 (JIS: Strength class 12.9) not less than 70mm and plain washers (option) of not less than 4.5 mm in thickness and HRC35 in hardness. At this time, apply a coating of lubricating oil to the threaded parts of the bolts, and then torque the bolts to 560 ± 30 N·m. Furthermore, to install the robot in an exact position, use location pins (option). If the floor concrete is not more than 150 mm in thickness, an independent foundation should be constructed. Inspect the foundation prior to the robot installation, and then construct the foundation, if necessary.

Robot model	Allowable repeated tensile load per foundation bolt when the robot is installed with 8 bolts
SRA100J-01	Approximately 24,000 N

■ Installation space

To install the robot, lock the swiveling base of the robot.

 CAUTION	The mechanical stopper end is located in a position exceeding the specified working envelope (software limit) of axis 1 by 3°. To install the safety fence, with consideration given to the wrist configuration and the shape of end effector.
 DANGER	On axes 1, 2 and 3, the robot working envelope can be regulated for safety (optional function). Since optional parts should be installed to enable this function, do not independently move the standard parts (e.g. mechanical stopper).

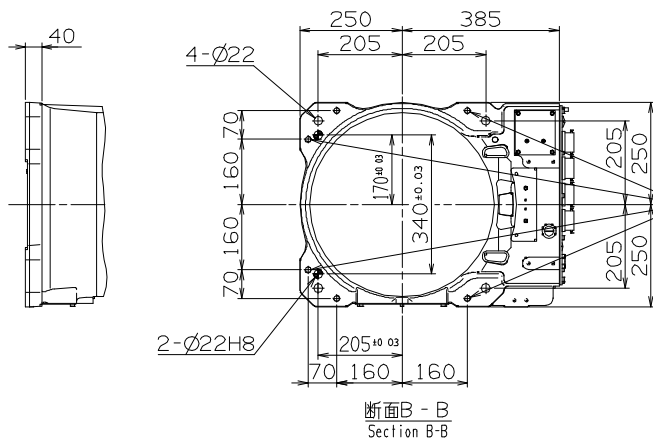
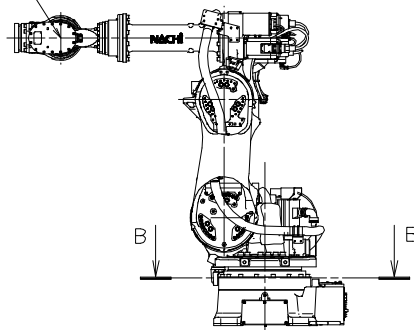
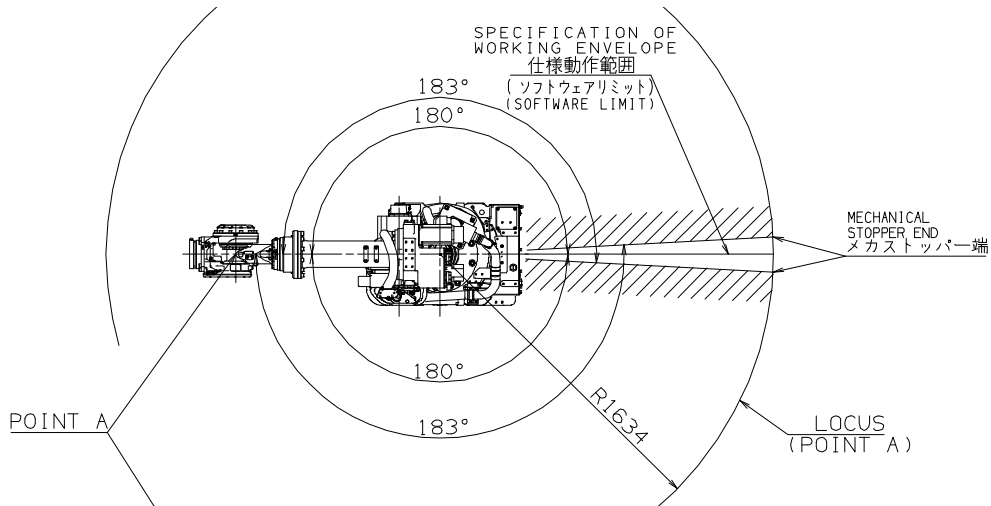

4 - M16
 ジャッキボルト使用時
 吊りボルトを取外してください。
 Remove eye bolts when
 use jack bolts.

※印のタップを
 ジャッキボルト
 には、使用しな
 いでください。 Do not use tap
 holes marked
 with symbol ※
 for jack bolts.

断面B - B
 Section B-B

■ Accuracy of installation surface

When installing robot, strictly observe precautions listed below to cause no deformation in the swivel base.

- (1) Make the deviation from the flatness of the 4 plates on the robot installation surface fall within 0.75 mm.
- (2) Make the deviation in height between the 4 places of each base plate installation surface and the robot installation surface fall in the range of 0.75 mm (± 0.375 mm).

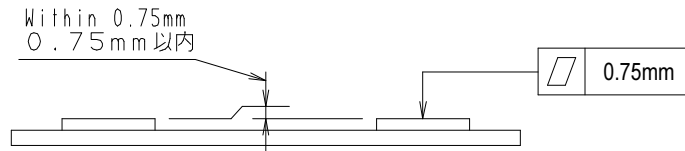

- (3) If the two precautions above cannot be observed, use jack bolts to bring the four places into even contact with the installation surface.

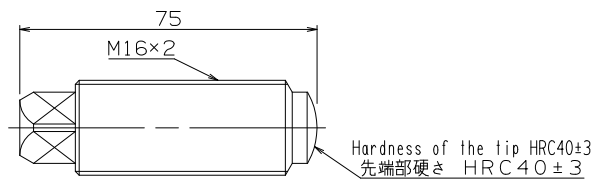

■ Welding of base plate

Protect the space (4 places of the front, back, left and right) on robot bottom and installed side by the cover etc. as follows when you weld with the base plate installed in the robot body by the welding spatter and the spark, etc. so that wiring in the robot should not receive damage. After welding the outer line, once remove the robot and weld the inner line.

Temporary install the robot, and weld the outer line of base plate.

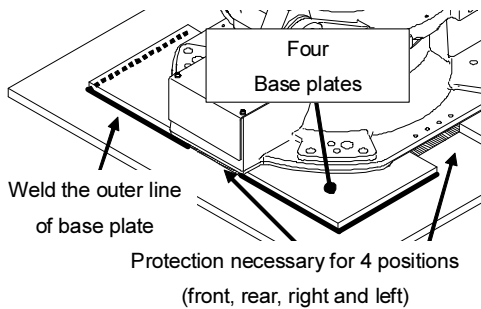

Once remove the robot and weld the inner line.

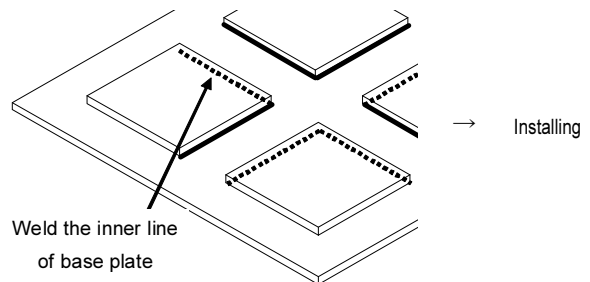

■ Maximum robot generative force

Robot model	Max. vertical generative force F_V	Max. horizontal generative force F_H	Max. vertical generative moment M_V	Max. horizontal generative moment M_H
SRA100J-01	28,100 N	20,700 N	36,600 N·m	31,500 N·m

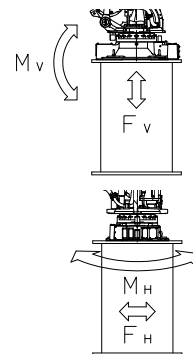

6. Allowable wrist load



Load fixed on the tip of wrist is regulated by “allowable payload mass”, “allowable static load torque”, and “allowable moment of inertia”. Strictly keep the wrist load within each allowable value. If wrist load exceeds the allowable value, this robot is out of guarantee. Refer to the table of “2. Basic specifications” and following figures for the detail of each specification.

■ Torque map

C.O.G. of wrist load should exist inside the range shown below.

[SRA100J-01]

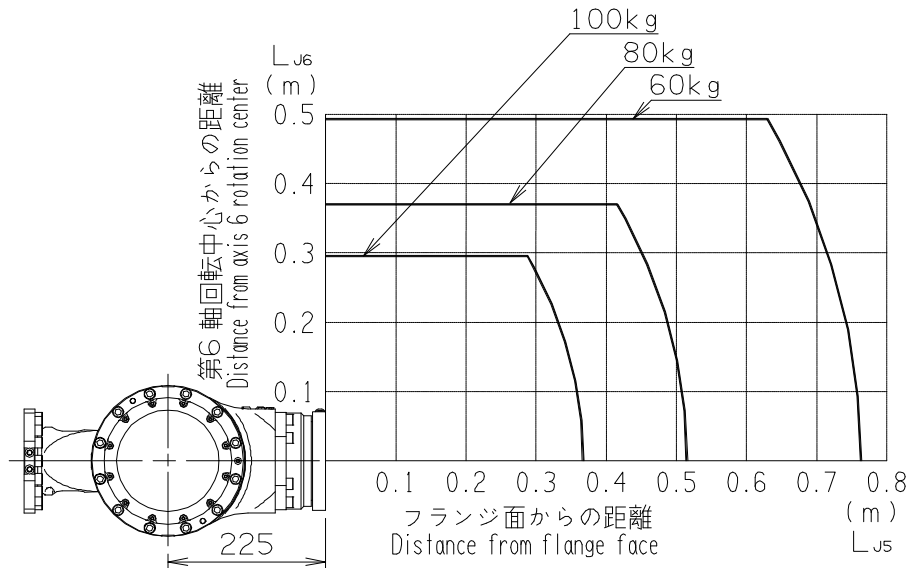

■ Moment of inertia map

Static load torque and moment of inertia of wrist load should exist inside the range shown below.



If the real inertia is over the limit written in “2. Basic specifications”, maximum speed will be restrained by software.

[SRA100J-01]

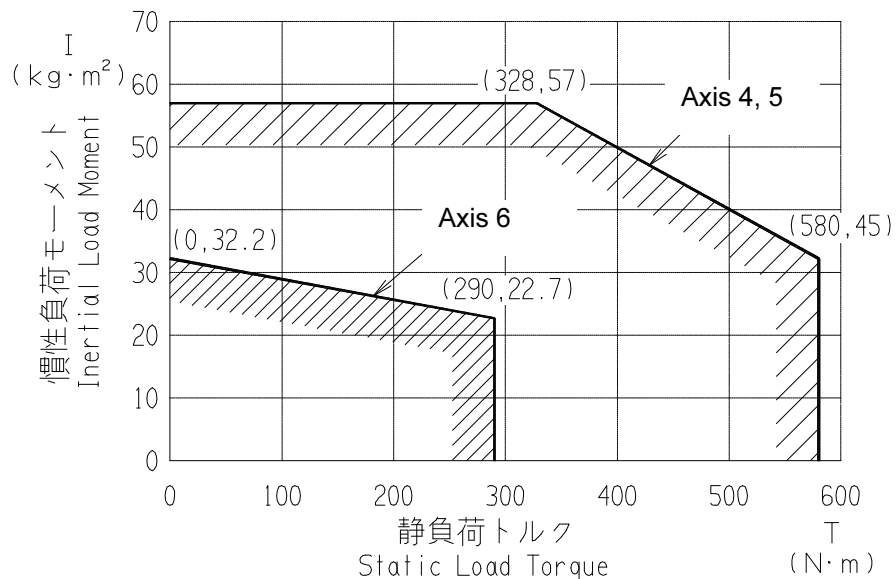

■ How to find the inertia moment of each axis

The following section shows general methods of calculating the inertia moment around each axis.

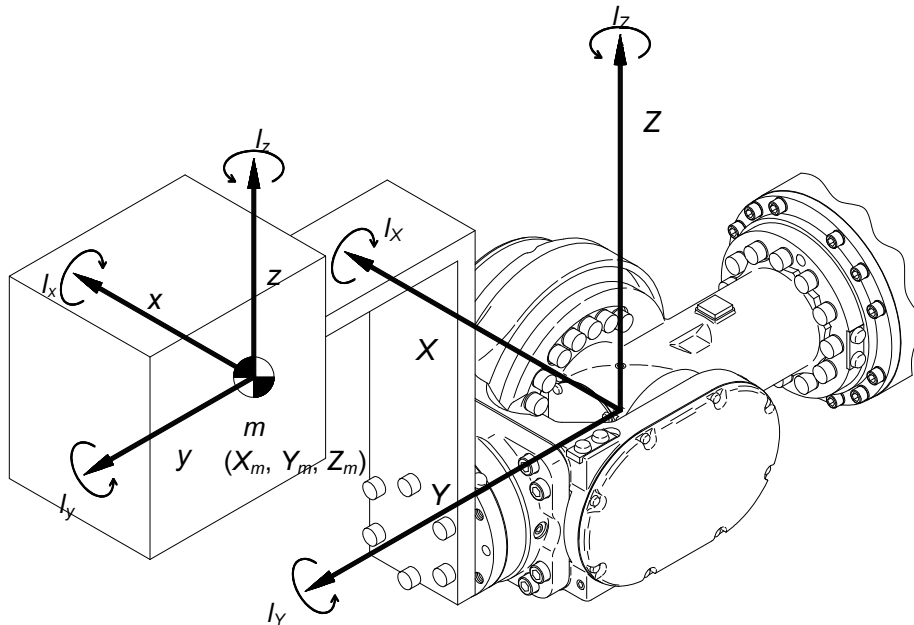

- X: Axis 5 rotation in the basic wrist configuration
- Y: Axis 6 and axis 4 rotation in the basic wrist configuration
- Z: Axis at right angles to the X and Y axes in the basic wrist configuration
- x: Axis parallel to the X axis in the load gravity center
- y: Axis parallel to the Y axis in the load gravity center
- z: Axis parallel to the Z axis in the load gravity center
- I_x : Inertia moment around the X axis passing through the load gravity center
- I_y : Inertia moment around the Y axis passing through the load gravity center
- I_z : Inertia moment around the Z axis passing through the load gravity center
- m : Load mass
- (X_m, Y_m, Z_m) : Gravity center coordinates of load

1. Inertia moment around axis 6

The inertia moment of around axis 6 is found by the expression shown below.

$$I_{J6} = I_y = m \cdot (X_m^2 + Z_m^2) + I_y$$

2. Inertia moment around axis 4 and axis 5

The inertia moment around axis 4 and axis 5 varies with axis 6 configuration. Consequently, in order to simplify the calculation, take a maximum value around the X and Z axes in above figure, as the inertia moment.

$$I_{J4J5} = \max (I_x , I_z)$$

$$\because I_x = m \cdot (Y_m^2 + Z_m^2) + I_x$$

$$\because I_z = m \cdot (X_m^2 + Y_m^2) + I_z$$

■ Allowable forearm load

Use the robot under condition that COG of the ancillary equipment on the forearm falls in the range shown below. When tool weight is lower than the rated value, weight of the ancillary equipment can be allowed up to 45Kg according to the tool weight.

[SRA100J-01]
When wrist load is 100kg

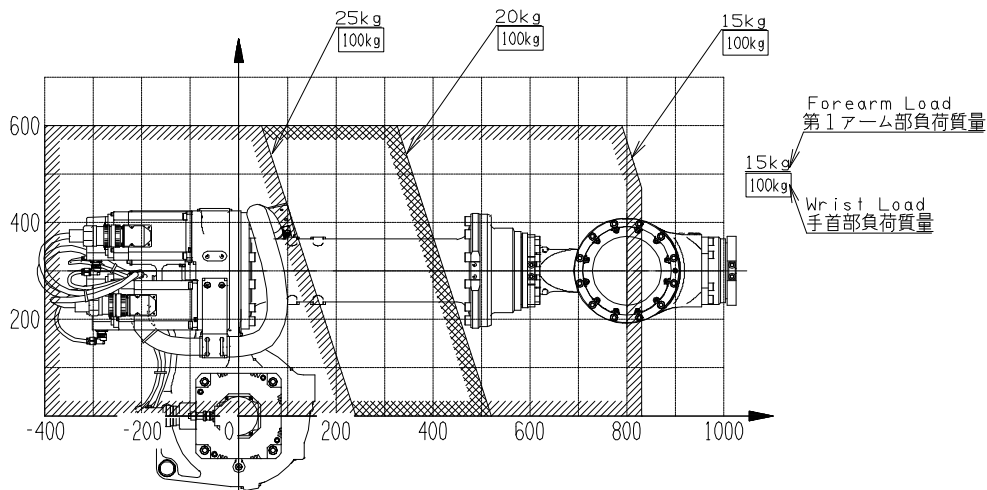

[SRA100J-01]
When wrist load is 70Kg

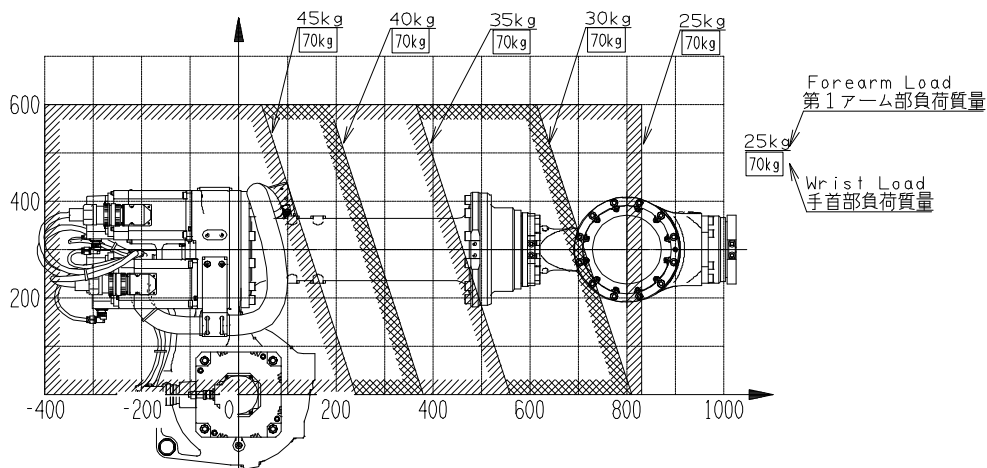

7. Option specifications

No.	Item	Specifications	Parts No.
1	Installation parts *1	Chemical anchor specification : with pin hole	OP-F1-029
		Base plate welded (anchors not included) : without pin hole	OP-F1-033
		Ore anchor specification : with pin hole	OP-F2-020
		Base plate welded (anchors not included) : without pin hole	OP-F2-021
		Pins set (Installation pins & polyethylene plug)	OP-F1-030
		Leveling plate (□180mm×t=32mm, 4 plates)	OP-F1-031
		Installation bolts & washers	OP-F1-032
2	Axis 1 adjustable stopper *1 *2 *3	Restriction of axis 1 operation edge (±3.14 rad - 0 rad, every 0.17 rad)	OP-S5-021
3	Axis 2 adjustable stopper	Restriction of axis 2 backward operation edge (+0.26rad, +0.52rad)	OP-A5-029
4	Big capacity application box *4	Big capacity BJ3 wiring junction box	OP-E5-005
5	Transfer jig	Fork bracket for floor mounting type	OP-S2-031
6	Zeroing pin & Zeroing block *1	For 100g payload	OP-T2-053
7	ISO Flange adaptor	Converts into the tool installation size with ISO	OP-W2-001
8	Flange adaptor	For 100 payload (P.C.D.92)	OP-W3-001
9	Wrist axis positioning marking	For 100g payload	OP-N3-006
10	Dual circuit limit switch	For axes 1, 2 and 3 (3pcs. of dual circuit LS)	OP-D7-012
11	Encoder connector Protector *5	For axis 3	OP-P6-005
12	Bypass cable *1		BCUNIT20-20
13	Scale seal	For wrist three axes	OP-N2-020
14	Water proof coolant Paint		OP-N5-033

*1 : These parts are packed separately from the robot. (Not attached on the robot)

*2 : A dog part for adjustable LS is included. If motion limit LS is not used, this dog is also not used.

*3 : Concerning the motion range limit options, please refer to the table in the next page.

*4 : When "big capacity application box" is mounted, robot width is enlarged from 500mm to 610mm (right figure).

*5 : Protector is attached for axis 1 and 2 as standard.

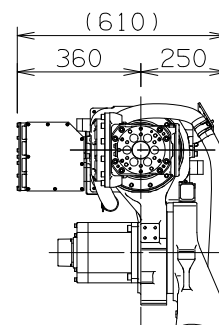

■ Please select "Motion range limit option" by referring to the following table.

Motion range limit option		Axis	Parts No.
Without LS	Only adjustable stopper	Axis 1	OP-S5-021
		Axis 2	OP-A5-029
		Axis 3	-
Dual circuit Limit Switch	Motion range Limit Switch	Axis 1·2·3 (3 pcs.set)	OP-D7-012
	Adjustable LS	Axis 2	OP-D7-012
		Axis 3	OP-D7-012
	Adjustable stopper and Adjustable LS	Axis 1	OP-D7-012 & OP-S5-021
		Axis 2	OP-D7-012 & OP-A5-029
		Axis 3	-

*1 : OP-S5-021 and OP-A5-029 are packed separately from the robot. (Not attached on the robot)

*2 : Axis 1 adjustable stopper and axis 1 adjustable LS dog are supplied in 1 package.

(Please be sure that even if only the stopper is used and no LS is used, dog is included in this package)

Axis 2 and 3 adjustable stopper are included in OP-D7-012.

8. Application wiring and piping diagram

■ Standard specification

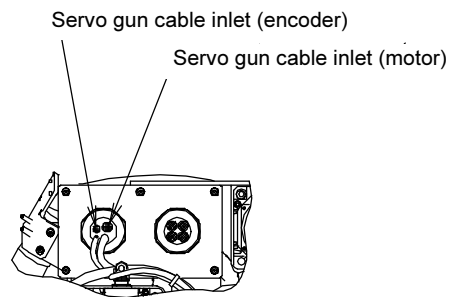
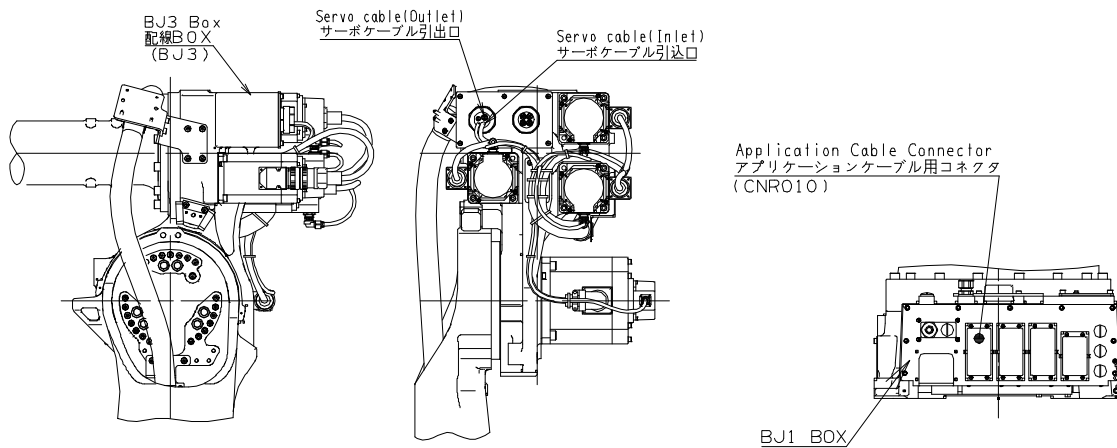
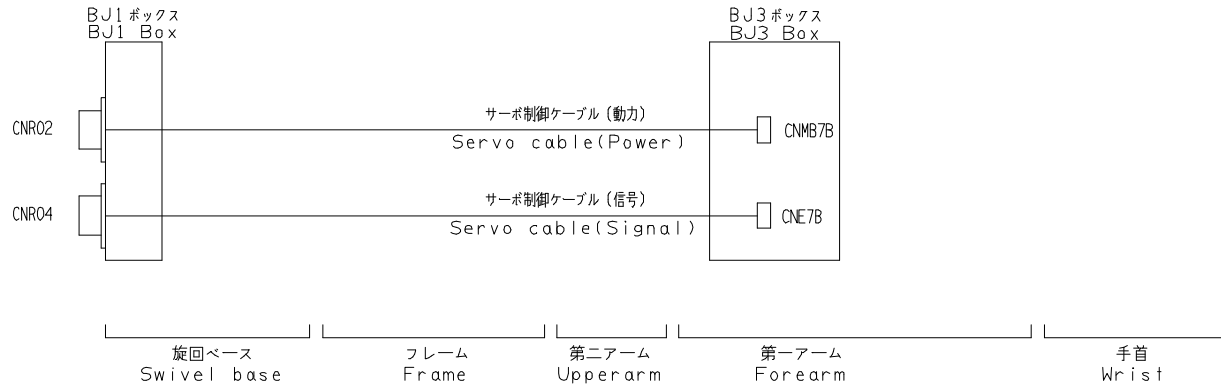

Detail of BJ3 BOX

■ Detailed diagram of the application connectors (option)

(1) BJ1 side (connector)

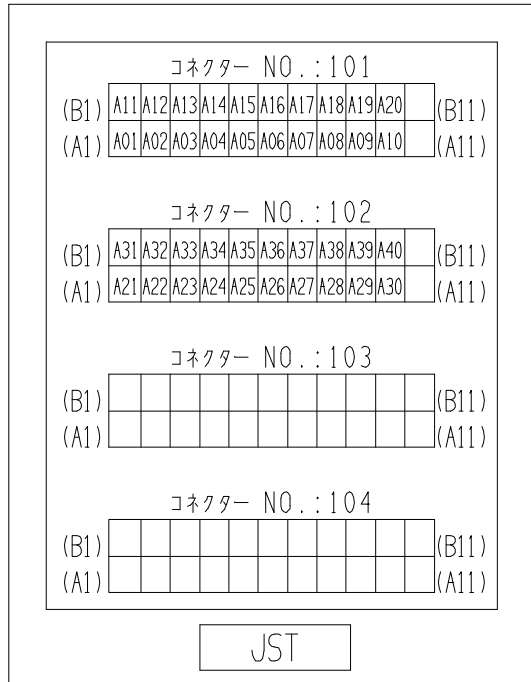

User-side Connectors

Wire-side shell: JFM-WSA-4-A (JST)
or JFM-WSA-4-C (JST)

Guide plate A kit: JFM-GPAK-4 (JST)

Receptacle housing: JFM2FDN-22V-K (JST)

Receptacle contact:

a: SJ2F-01GF-P1.0 (JST) (0.20 ~ 0.50sq)

b: SJ2F-21GF-P1.0 (JST) (0.30 ~ 0.75sq)

Manual crimp tool:

a: YRS-8861

b: YRF-1120

Cable diameter suitable for wire-side shell:

JFM-WSA-4-A φ26.2~φ28.0

JFM-WSA-4-C φ15.5~φ16.5

(Pin location shows the connector mounted on robot body and is the view from connecting side.)

Application wiring specification

Rated voltage Max. AC/DC 115 V

Rated current rating Max. 1 A

(2) BJ3 side (connector)

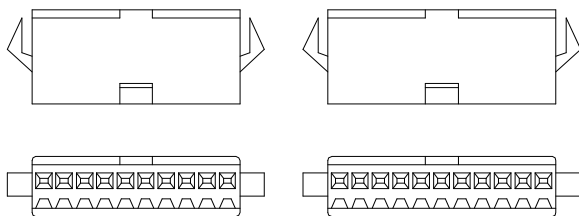

CN61

1	2	3	4	5	6	7	8	9	10
A01	A02	A03	A04	A05	A06	A07	A08	A09	A10

CN62

1	2	3	4	5	6	7	8	9	10	11
A11	A12	A13	A14	A15	A16	A17	A18	A19	A20	E

CN63

1	2	3	4	5	6	7	8	9	10
A21	A22	A23	A24	A25	A26	A27	A28	A29	A30

CN64

1	2	3	4	5	6	7	8	9	10	11
A31	A32	A33	A34	A35	A36	A37	A38	A39	A40	E

Connector form (CN61, CN63)

Housing SMP-10V-BC (JST)

User-side Connectors

Housing SMR-10V-B (JST)

Contact SYM-001T-P0.6 (Wire of Application : AWG#22~28)

Pressure tool YRS-121

Connector form (CN62, CN64)

Housing SMP-11V-BC (JST)

User-side Connectors

Housing SMR-11V-B (JST)



Contact SYM-001T-P0.6 (Wire of Application : AWG#22~28)

Pressure tool YRS-121

9. Transport procedure

Safety measures against transport

The following describes precautions for transporting the robot. Fully understand the precautions for safe transport work.

 WARNING	The robot must be transported by personnel who have licenses required for slinging work, crane operation, forklift truck operation, and others. The weight of the robot and controller is listed in the Operating Manual and the Maintenance Manual. Check for the weight, and then handle them according to procedures suitable for the weight.
 WARNING	To lift the robot or the controller, follow the procedures specified in the Maintenance Manual. Following any procedures other than those specified will cause the robot to topple over or drop during transport, thus resulting in accidents.
 WARNING	During transport or installation work of the robot, pay utmost care not to cause damage to wirings. Furthermore, after installing the robot, take protective measures such as using protective guards so that the wirings will not be damaged by workers or other persons, or forklift trucks or else.

To transport the robot, make it a rule to use a crane.

At first, put the robot into the configuration shown in figure below and mount the four M16 hanger bolts to the swivel base. Then, be sure to lift the robot using four hanging wires. For this purpose, it is recommended to use hanging wires of 3 m in length and protect areas that contact the robot, using rubber hoses to cover the wire ropes. For the areas to be covered with the rubber hoses refer to figure below.

[SRA100J-01]

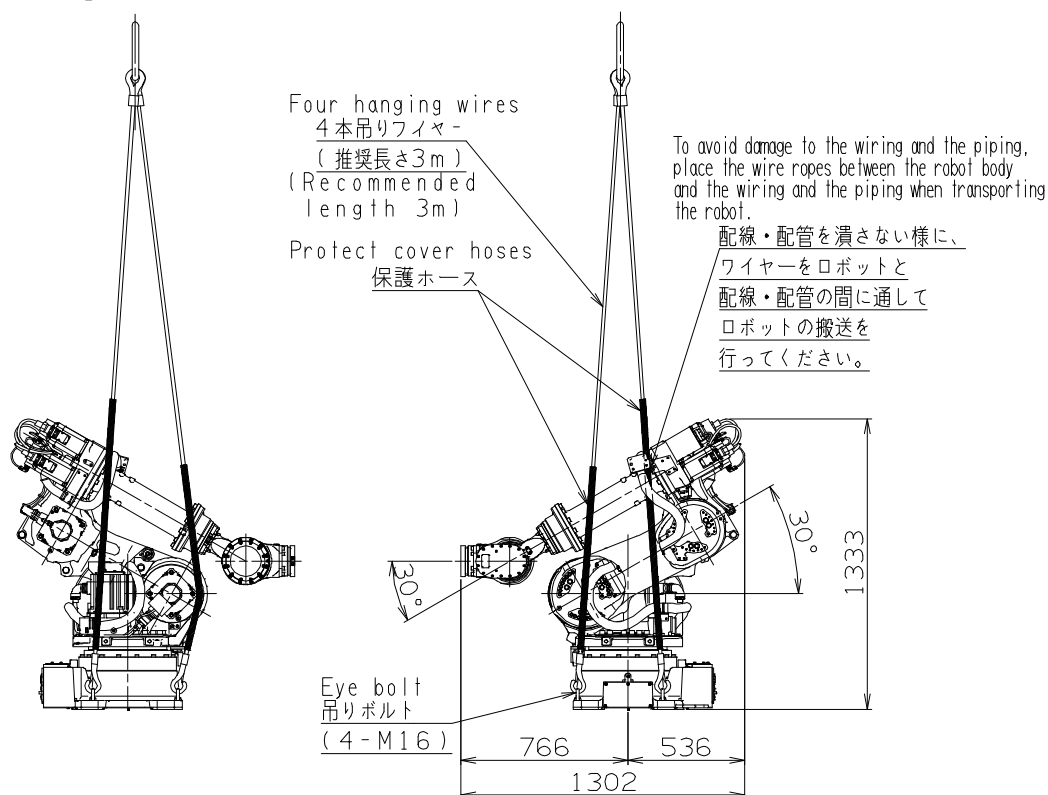

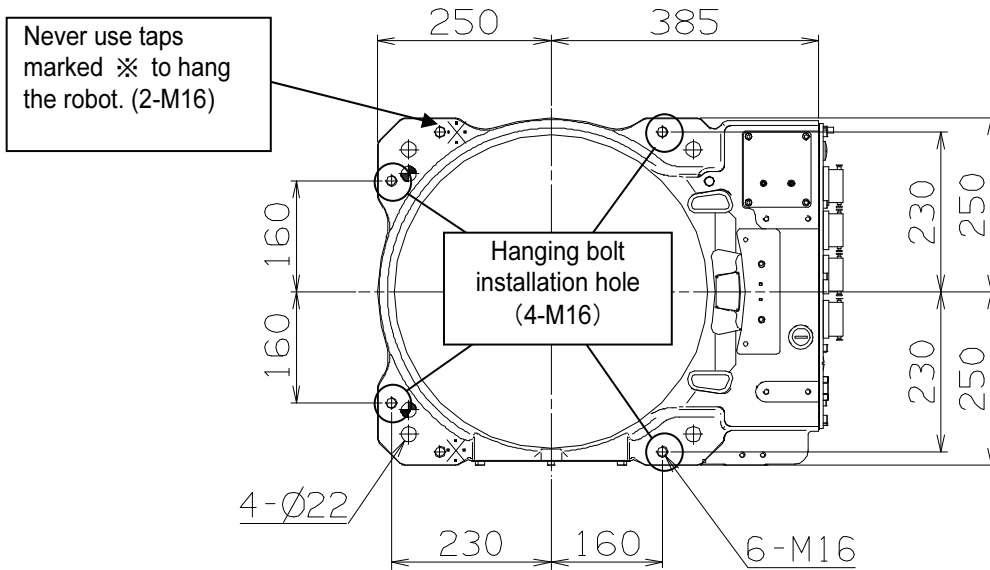

If hanging wires push the encoder connectors or wiring/piping, they may be broken when hanging the robot. When hanging the robot, please pay attention not to make the wires touch the encoder connectors and wiring/piping.

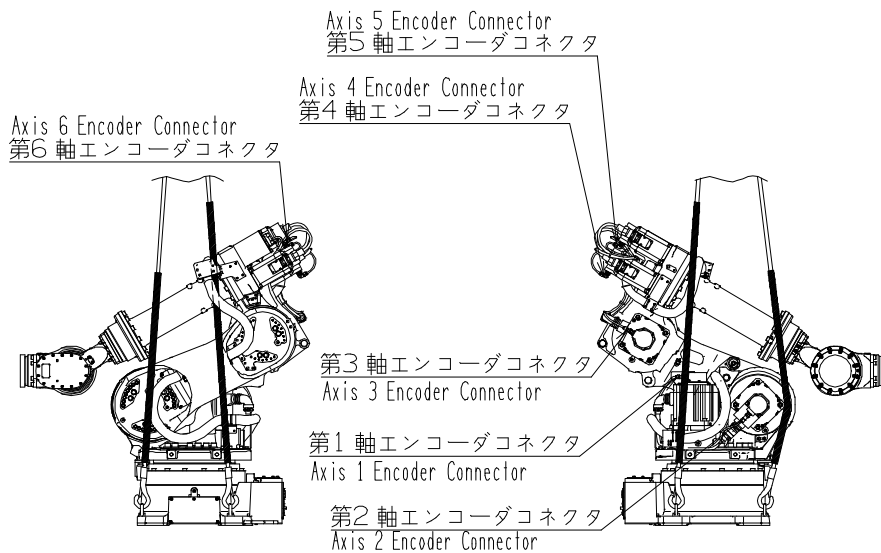

10. Delivery style (specification which contains a robot)

1. There are three styles as shown below.

	Style	Details
1	Delivery on the truck	Robot is delivered on the truck near the entrance of customer's plant. (Installation and test-run is not included)
2	Delivery after installation and test-run	Robot is installed and test-run is done. (Teaching with work piece is not included.)
3	Delivery after installation and teaching with work piece	After style 2, teaching with work piece is done.

Because the expense is different, which form to choose be sufficiently examined.

2. Operation and maintenance education

The special spot operation guide and the special spot preservation guide are the outside of the estimation. Consult with each NACHI-FUJIKOSHI office for the details as for the schooling system.

11. Consuming power (Robot + Controller)

7.0 kVA (may vary according to the application and motion pattern.)

12. Paint color

Standard color Controller cabinet Munsell 10GY9/1
 Robot body Munsell 10GY9/1

13. Warranty

Elapse of 1 year after delivery. (8 hours/day running)

The specification and externals described in this specifications might change without a previous notice for the improvement.

NACHI NACHI-FUJIKOSHI CORP.		http://www.nachi-fujikoshi.co.jp/	
JAPAN MAIN OFFICE	Phone: +81-3-5568-5245	Fax: +81-3-5568-5236	Shiodome Sumitomo Bldg. 17F, 1-9-2 Higashi-Shinbashi Minato-ku, TOKYO, 105-0021 JAPAN
NACHI NORTH AMERICA		http://www.nachirobotics.com/	
North America Headquarters	Phone: 248-305-6545	Fax: 248-305-6542	22285 Roethel Drive, Novi, Michigan 48375 U.S.A.
Greenville Service Office	Use 248-305-6545	Use 248-305-6542	South Carolina, U.S.A.
San Antonio Service Office	Use 248-305-6545	Use 248-305-6542	Texas, U.S.A.
Kentucky Branch Office	Phone: 502-695-4816	Fax: 502-695-4818	116 Collision Center Drive, Suite A, Frankfort, KY 40601 U.S.A
Training Office	Phone: 248-334-8250	Fax: 248-334-8270	22213 Roethel Drive, Novi, Michigan 48375 U.S.A.
Toronto Branch Office	Phone: 905-760-9542	Fax: 905-760-9477	89 Courtland Avenue, Unit 2, Vaughan, Ontario L4K3T4 CANADA
Mexico Branch Office	Phone : +52-555312-6556	Fax: +52-55-5312-7248	Urbina # 54, Parque Industrial Naucalpan, Naucalpan de Juarez, 53370, Estado de México, MEXICO
Saltillo Service Office	Phone : +52-844416-8053	Fax: +52-844416-8053	Canada 544 Privada Luxemburgo C. P. 25230, Saltillo, Coahuila, MEXICO
NACHI ROBOTIC EUROPE		http://www.nachi.de/	
Germany			
Nachi Europe GmbH	Phone: +49-(0)2151-65046-0	Fax: +49-(0)2151-65046-90	Bischofstrasse 99, 47809, Krefeld, GERMANY
United Kingdom		http://www.nachi.co.uk/	
Nachi U.K. LTD.	Phone: +44-(0)121-250-1895	Fax: +44-(0)121-250-1899	Unit 7, Junction Six Industrial Estate, Electric Avenue, Birmingham B6 7JJ, U.K.
Czech Republic			
Nachi Europe	Phone: + 420-255-734-000	Fax: +420-255-734-001	Prague 9, VGP Park, Czech republic
NACHI ROBOTIC ASIA		http://www.nachi-korea.co.kr/	
Korea			
Korea	Phone: +82-(0)2-469-2254	Fax: +82-(0)2-469-2264	2F Dongsan Bldg. 276-4, Sungsu 2GA-3DONG, Sungdong-ku, Seoul 133-123, KOREA

Copyright NACHI-FUJIKOSHI CORP.

Robot Division

1-1-1, FUJIKOSHIHONMACHI, TOYAMA CITY, JAPAN 930-8511
Phone +81-76-423-5137
Fax +81-76-493-5252

NACHI-FUJIKOSHI CORP. holds all rights of this document. No part of this manual may be photocopied or reproduced in any form without prior written consent from NACHI-FUJIKOSHI CORP. Contents of this document may be modified without notice. Any missing page or erratic pagination in this document will be replaced.

In case that an end user uses this product for military purpose or production of weapon, this product may be liable for the subject of export restriction stipulated in the Foreign Exchange and Foreign Trade Control Law. Please go through careful investigation and necessary formalities for export.

Original manual is written in Japanese.

NACHI-FUJIKOSHI CORP. ©