

SH133/133T/166/166T FOOT AND WRIST

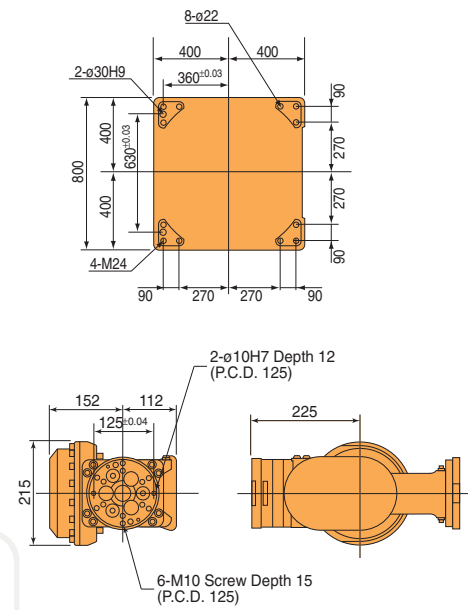

SH200/200T FOOT AND WRIST

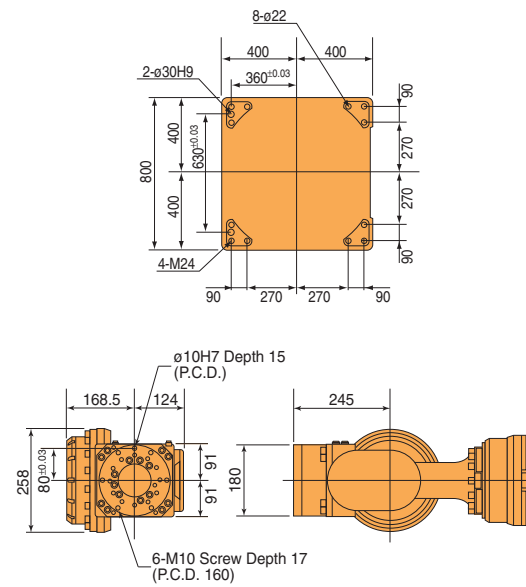

Notes

Presto

NACHI
NACHI ROBOTIC SYSTEMS INC.

SH133/133T/166/166T/ 200/200T

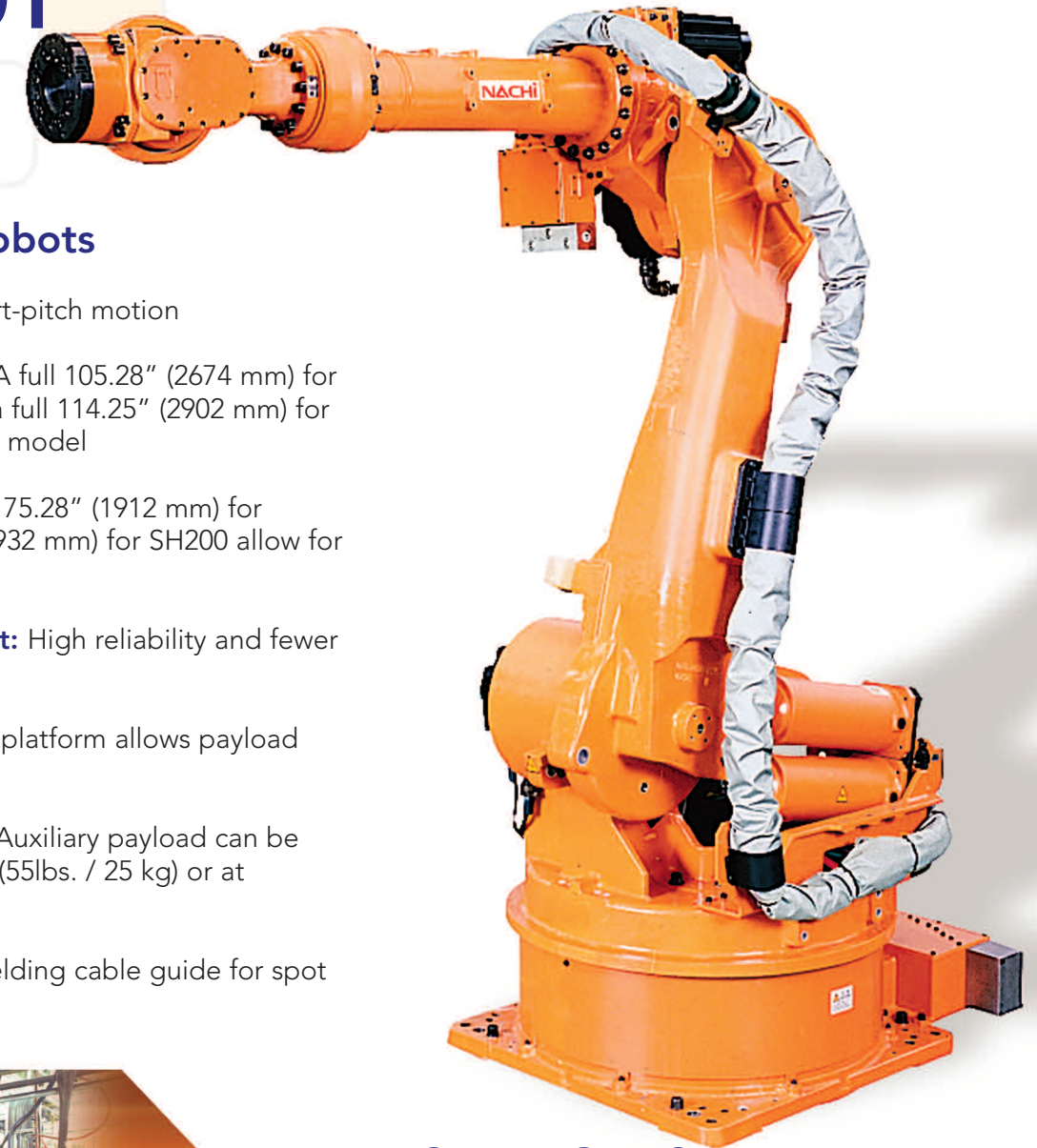

Large Envelope Robots

High Speed: Improved short-pitch motion

Large Working Envelope: A full 105.28" (2674 mm) for the 441 lb. (200 kg) model; a full 114.25" (2902 mm) for the 366 lb (166 kg) long-arm model

Versatile Backward Reach: 75.28" (1912 mm) for SH133/SH166 and 76.06" (1932 mm) for SH200 allow for quick material handling

Reduced Maintenance Cost: High reliability and fewer lubrication points

Modular Design: Common platform allows payload changes in the field

Large Payload Capability: Auxiliary payload can be mounted on the upper arm (55lbs. / 25 kg) or at axis 3 (99 lbs. / 45 kg)

Built-in S-TRAC: Internal welding cable guide for spot welding is standard



APPLICATIONS

- | | | |
|--------------|-------------------------|----------------|
| Spot Welding | Sealing | Loading |
| Handling | Press-to-Press Handling | Die-Casting |
| Deburring | Assembly | Roller Hemming |
| Palletizing | | Press Brake |

NACHI
NACHI ROBOTIC SYSTEMS INC.

SH133/133T/166/166T/200/200T



BASIC SPECIFICATIONS

		SH133	SH133T	SH166	SH166T	SH200	SH200T	
Construction		Articulated						
Numbers of Axes		6						
Drive		AC Servo Motor						
Loading Weight		Wrist 133 kg Forearm 45 kg	Wrist 133 kg Forearm 45 kg	Wrist 166 kg Forearm 45 kg	Wrist 166 kg Forearm 45 kg	Wrist 200 kg Forearm 45 kg	Wrist 200 kg Forearm 45 kg	
Maximum Stroke	Arm	J1 Swivel	±180°	±180°	±180°	±180°	±180°	
		J2 Back & Forth	-60° ~ +80°	-65° ~ +120°	-60° ~ +80°	-65° ~ +120°	-60° ~ +80°	-65° ~ +120°
		J3 Up & Down	-132° ~ +258°	-105° ~ +210°	-132° ~ +258°	-105° ~ +210°	-132° ~ +258°	-105° ~ +210°
	Wrist	J4 Rotation 2	±360°	±360°	±360°	±360°	±360°	±360°
		J5 Bend	±135°	±135°	±135°	±135°	±130°	±130°
		J6 Rotation 1	±360°	±360°	±360°	±360°	±360°	±360°
Maximum Velocity	Arm	J1 Swivel	100°/sec	100°/sec	100°/sec	100°/sec	100°/sec	
		J2 Back & Forth	90°/sec	90°/sec	90°/sec	90°/sec	90°/sec	90°/sec
		J3 Up & Down	95°/sec	95°/sec	95°/sec	95°/sec	95°/sec	95°/sec
	Wrist	J4 Rotation 2	225°/sec	225°/sec	150°/sec	150°/sec	120°/sec	120°/sec
		J5 Bend	225°/sec	225°/sec	150°/sec	150°/sec	120°/sec	120°/sec
		J6 Rotation 1	305°/sec	305°/sec	210°/sec	210°/sec	190°/sec	190°/sec
Wrist Torque	J4 Rotation 2	76 kg·m	76 kg·m	97 kg·m	97 kg·m	130 kg·m	130 kg·m	
	J5 Bend	76 kg·m	76 kg·m	97 kg·m	97 kg·m	130 kg·m	130 kg·m	
	J6 Rotation 1	45 kg·m	45 kg·m	50 kg·m	50 kg·m	70 kg·m	70 kg·m	
Allowable Moment of Inertia	J4 Rotation 2	60.9 kg·m ²	60.9 kg·m ²	88.9 kg·m ²	88.9 kg·m ²	117.3 kg·m ²	117.3 kg·m ²	
	J5 Bend	60.9 kg·m ²	60.9 kg·m ²	88.9 kg·m ²	88.9 kg·m ²	117.3 kg·m ²	117.3 kg·m ²	
	J6 Rotation 1	30.2 kg·m ²	30.2 kg·m ²	44.1 kg·m ²	44.1 kg·m ²	65.9 kg·m ²	65.9 kg·m ²	
Repeatability		±0.3 mm						
Ambient Temperature		0~45°C (32~113°F)						
Installation		Floor		Shelf		Shelf		
Robot Body Weight		1,260 kg		1,330 kg		1,375 kg		

OPERATING RANGES

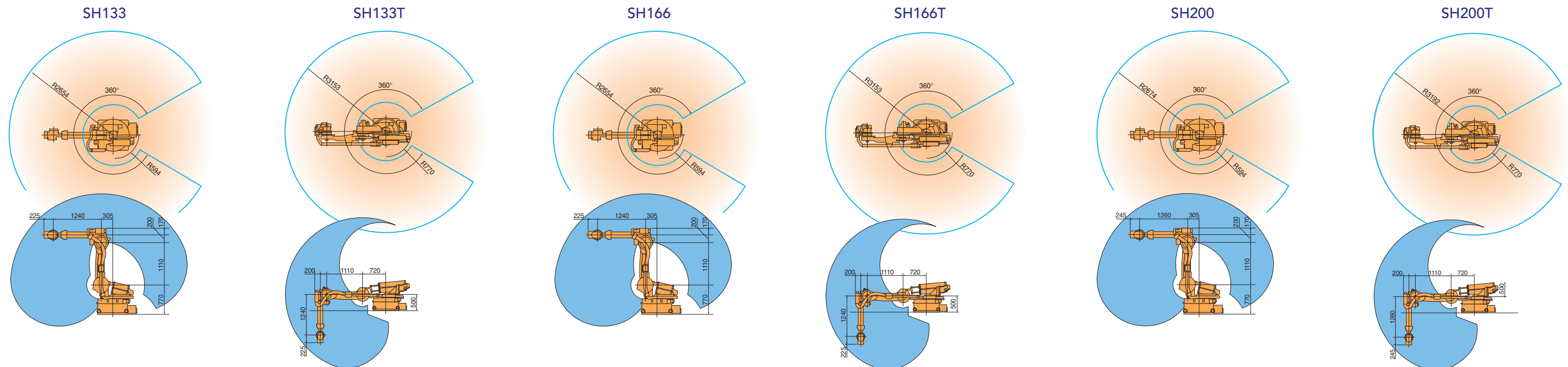

For more information and specifications, please visit www.nachirobotics.com